

# METAL-ENCLOSED SWITCHGEAR INDOOR AND OUTDOOR DISTRIBUTION 5kV THROUGH 38 kV



*Automatic Source Transfer*



*Manual with Metering Bay  
Category B Enclosure*

## Metal-Enclosed Switchgear - Advantages

Around industrial plants, universities, waste water treatment facilities, convention centers and similar other large facilities usually there is a need to distribute electrical power located below the ground surface at medium voltage (5kV - 38kV) via cable circuits. Typically, these circuits are connected to a central assembly of switchgear, fed by a main circuit from the local utility, and arranged in lineups of multiple cubicles.

There are basically two types of Medium-Voltage (MV) Switchgear lineups: Metal-Clad (containing drawout circuit breakers) and Metal-Enclosed (containing loadbreak switches and fuses). The fuses used in Metal-Enclosed equipment can be either **expulsion** or **current limiting**. Figure 1 represents the relative energy-limiting capabilities of MV breakers, expulsion fuses and current-limiting fuses, which in the case of Metal-Enclosed switchgear utilizes expulsion and current-limiting fuses for protection to provide the best energy limitation.

These two types of medium-voltage switchgear lineups of cubicles are defined in ANSI Standards (C37.20.2 for Metal-Clad and C37.20.3 for Metal-Enclosed). Criteria for selecting one of these two types of switchgear should be: security, ease of operation, the quality of protection offered, first cost and life-cycle cost.

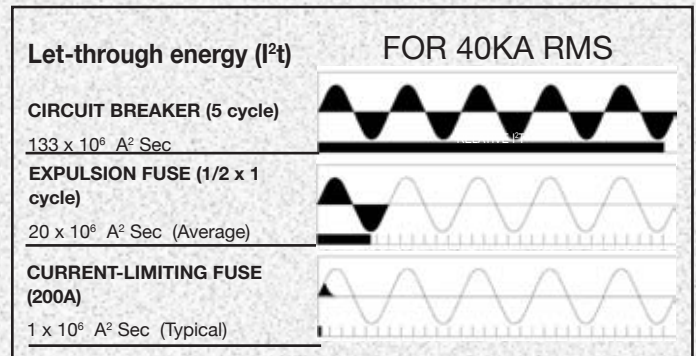

*Figure 1. Relative energy limitation of damaging let-through currents provided by various protective devices.*

Figure 2 below is a summary table of features favoring the selection of Metal-Enclosed lineups with switches and fuses:

While Metal-Enclosed Switchgear using load-interrupter switches and fuses has many economic and protective advantages over Metal-Clad using circuit breakers, Federal Pacific, whose predominant construction is Metal-Enclosed, will use a drawout circuit breaker to handle high, **continuous** load-currents that exceed the fuse rating of a switch and fuse combination or for automatic reclosing. Since faults on industrial power systems are almost always "permanent", automatic reclosing is not desirable because subsequent reclosing will only cause further damage to cables and equipment. Thus, Metal-Enclosed switchgear lineups are the better choice.

#### Advantages of Metal-Enclosed over Metal-Clad

- Lower Initial Cost per cubicle (Metal-Enclosed = 1/3 of Metal-Clad)
- Better protection for cables and transformers
- Significantly lower let-thru currents (mechanical energy)
- Significantly lower let-thru I<sup>2</sup>T (thermal energy)

(Breakers take 5 cycles from relay sensing to circuit interruption. Power fuses require no more than 1 cycle for circuit interruption.)

- Lower installation cost (simple field assembly)
- No auxiliary power or VTs are needed
- No maintenance required for fuses
- No possibility of reclosing on a fault with fuses
- Single-phase protection: Shunt trip of three-phase switch in feeder cubicle when a fuse operates

Figure 2. Advantages of Metal-Enclosed Switchgear compared to Metal-Clad Switchgear.

Voltage Class	Type of O.C. Protection	Width (in inches)		Height (in Inches) ②	Depth (in Inches) ③
		Manual	Motor Operated		
5kV	Current Limiting ④	36	46	90	46
	Draw-out VCB	36	—	90	94
	Expulsion Fuse	41	46	90	46
15kV	Current Limiting ④	36	46	90	46
	Draw-out VCB	36	—	90	94
	Expulsion Fuse	41	46	90	46
25kV	Current Limiting ④	—	—	—	—
	Expulsion Fuse	48	53	120	48
35kV	Current Limiting ④	—	—	—	—
	Expulsion Fuse	60	—	130	60

① Dimensions are for standard production products.

② Add 5.5 inches to the height for Outdoor NEMA 3R enclosures.

③ If rear-entry compartment is needed, increase the depth of the compartment by the following dimensions:

**5kV**-add 16 inches

**15kV**-add 16 inches

**25 kV**-add 24 inches

**35kV**-add 30 inches

④ G&W *Commutating* Current-Limiting fuses are available for all voltages 5-38kV. Contact factory for dimensions.

## Metal-Enclosed Switchgear Application

Federal Pacific Metal-Enclosed Load-Interrupter Switchgear provides a secure, convenient method for switching and overcurrent protection of high-voltage cable systems. The switchgear may be located indoors or outdoors. Typical applications include:

- Service entrance switching.
- Transformer primary and secondary switching.
- Isolation and protection of feeder circuits.
- Loop circuit sectionalizing.
- Manual and automatic transfer from preferred to emergency circuits.

Federal Pacific Metal-Enclosed Switchgear has been designed to meet the most rigid requirements for this class of equipment. High grade 11-gauge steel panels are designed so that each switchgear bay is an individual self-supporting unit with double walls between bays on multiple bay lineups.

Corrosion-resistant cabinets are assured by chemical cleaning and phosphatizing followed by a rust-resistant baked powder epoxy prime coat followed by a baked-on polyurethane finish coat that is UL Listed for NEMA1 and NEMA 3R installations. Powder coats are applied using electro-static deposition. Standard color is light gray, ANSI 61.

The Auto-Jet® II loadbreak switch is equipped with a quick-make, quick-break stored-energy mechanism. The operating handle is mounted on the right front of the unit at a convenient level with a maximum upward swing of 78" above ground level. The maximum operating force is 60 pounds. The standard manual operating handle may be padlocked either open or closed. A mechanical interlock is provided as standard to prevent opening the door with the switch closed or closing the switch with the door open. Optional key interlocks to replace mechanical interlocks as well as other key-interlock systems are available. Inspection windows are located so that the position of the switch blades may be checked with the exterior bulkhead door closed.

Standard switchgear main bus is rated 600 amperes, 40,000 asymmetrical rms amperes momentary. Optional main bus rating of 1200 amperes is available to 61,000 asymmetrical amperes momentary.

Switch Ratings						
kV		Amperes				60 HZ Withstand kV
Nom.	Max. Design	Continuous & Interrupting	Momentary RMS ASYM†	Fault-Closing RMS ASYM†	BIL kV	
4.8	5.5	600	40,000	40,000	60	19
4.8	5.5	1200	40,000	40,000	60	19
14.4	17.0	600	40,000	40,000	95	36
14.4	17.0	1200	40,000	40,000	95	36
14.4	15.5	1200	61,000†	61,000†	110	36
25	27	600	40,000	40,000	125	60
25	27	1200	40,000	40,000	125	60
34.5	38	600	40,000	40,000	150	80
34.5	38	600*	61,000	40,000	200	60

† The Auto-jet® Switch has a three-time fault-close capability at 40kA and a single-time fault-close capability at 61kA per ANSI standards.

\* The switch has a loadbreak rating of 600 amperes and a continuous current rating of 1200 amperes.



- UL® Listed (5 & 15kV)
- Meets ANSI C57.12.28 enclosure security requirements
- 11-gauge steel
- Auto-jet® II puffer-type load-interrupter switch
- Three-time duty-cycle fault-closing switch
- No rear access required
- Easy inspection and maintenance



Manual  
Metal-Enclosed Switchgear

## Applicable Industry Standards

**ANSI C37.22** – Preferred Ratings and Related Capabilities for Indoor AC Medium-Voltage Switches Used in Metal-Enclosed Switchgear

**IEEE C37.30** – Requirements for High-Voltage Air Switches

**ANSI C37.72** – High-Voltage Switches, Bus Supports, and Accessories – Schedules of Preferred Ratings, Construction Guidelines, and Specifications

**ANSI C37.34** – Test Code for High-Voltage Air Switches

**ANSI C37.57** – Metal-Enclosed Interrupter Switchgear Assemblies – Conformance Testing

**ANSI C37.58** – Indoor AC Medium-Voltage Switches for use in Metal-Enclosed Switchgear – Conformance Test Procedures

**IEEE C37.74** – Standard Requirements for Subsurface, Vault, and Pad-Mounted Load-Interrupter Switchgear and Fused Load-Interrupter Switchgear for Alternating Current Systems up to 38kV

## Single-Bay Manual Metal-Enclosed Switchgear - Construction

Most single-bay Metal-Enclosed Switchgear is applied for the HV Switch and Fuse protection of medium-voltage industrial transformers either liquid filled or dry type in the 500-5000 KVA range. This switchgear can be furnished in NEMA 1 and NEMA 3R construction in the cabinet security classifications of Category A, Category B or Category C.

There are two important economic considerations for selecting the design of single-bay assemblies for transformer switching applications. First, there will be considerable savings by having the switchgear cubicle "closely coupled" to the transformer primary either by flange connection or throat connection. This configuration eliminates the need for additional cable and stress relieving terminations in both the switchgear and transformer and

also eliminates the need for an additional rear-entry compartment when bottom cable entry and bottom cable exit are required from a "stand-alone" cubicle.

Second, strong consideration should be given to selecting current-limiting fuses for circuit protection inside the cubicle. Current-limiting fuses provide significantly better fault energy limitation than expulsion fuses in terms of lower "peak let-thru current" (mechanical energy that deforms windings) and lower I<sup>2</sup>T energy (thermal energy that damages insulation). The initial cost of ME cubicles housing current-limiting fuses is about 25% less than ME cubicles housing expulsion fuses, which during operation can leave significant residue on insulating barriers and cabinet walls.

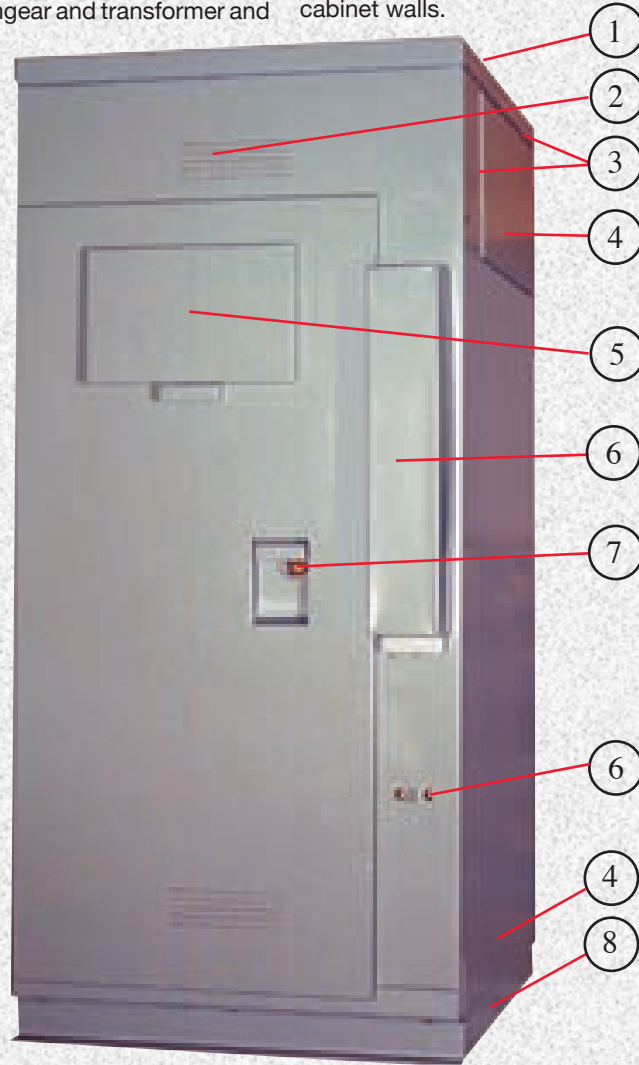

1. Lifting angles, at top of enclosure (shown on next page) are removable with bolt holes blind-tapped.
2. Screened ventilation perforations include an internal backup plate.
3. Weather sealant between roof and enclosure and between bus extension cover plate and enclosure.
4. Heavy-gauge steel cover plates over main and ground bus openings.
5. Security cover (optional) over viewing window is hinged and padlockable for Category A installations.
6. Security cover (optional) over switch operating handle can be positioned over handle in either the open or closed position and is padlockable in either location for Category A installations. Lower location shows bottom position of cover when switch handle is in open position.
7. Door handle is recessed, includes penta-head bolt and is padlockable. (Category A only).
8. Channel base of heavy-gauge steel supports enclosure.

*Exterior view of an outdoor, Category A, single-bay 15 kV metal-enclosed switchgear enclosure containing an Auto-jet® II load-interrupter switch with power fuses.*

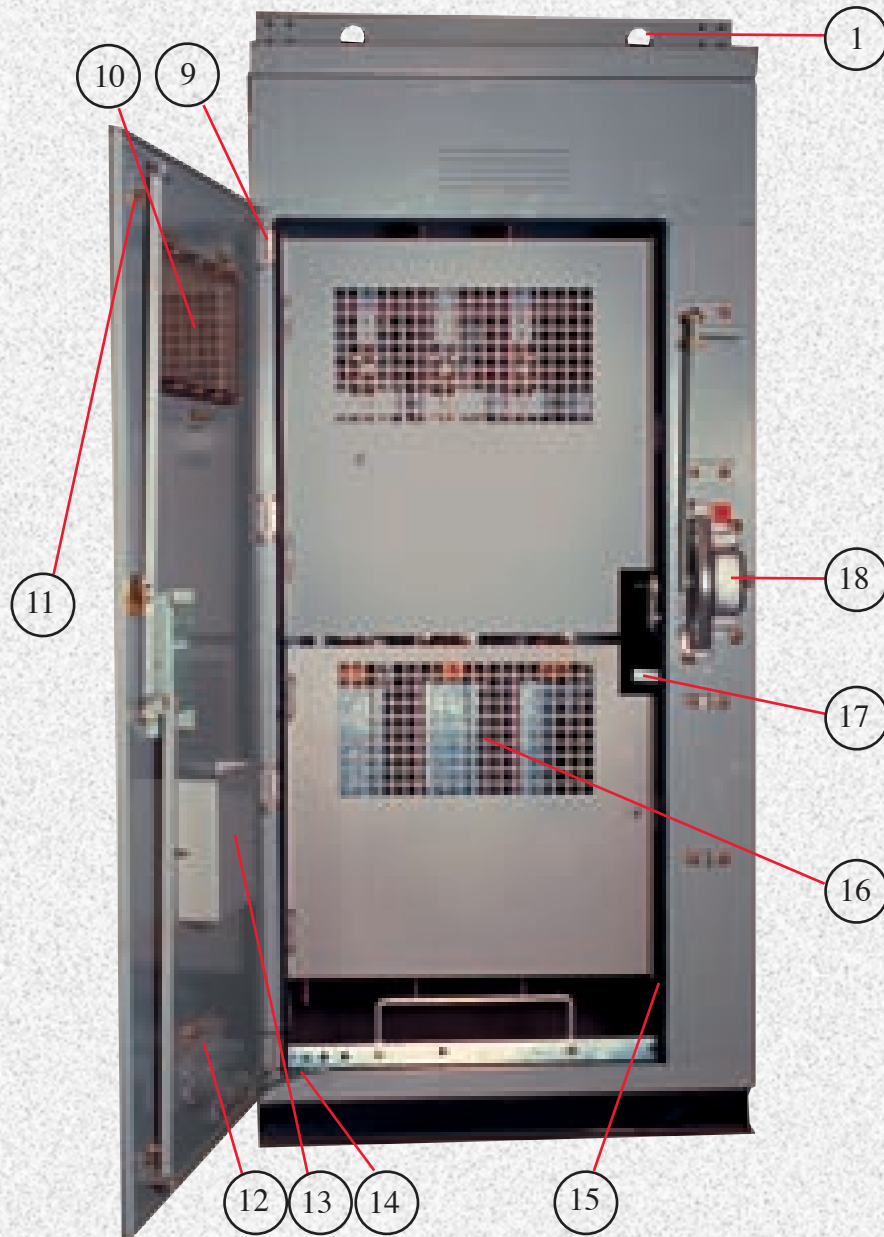

- |                                                                                                                                                                                                                                                                                                                                                                                                                                  |                                                                                                                                                                                                                                                                                                                                                                                                                                                                           |
|----------------------------------------------------------------------------------------------------------------------------------------------------------------------------------------------------------------------------------------------------------------------------------------------------------------------------------------------------------------------------------------------------------------------------------|---------------------------------------------------------------------------------------------------------------------------------------------------------------------------------------------------------------------------------------------------------------------------------------------------------------------------------------------------------------------------------------------------------------------------------------------------------------------------|
| <p>9. Stainless-steel door hinges and pins ensure easy movement of doors throughout equipment life.</p> <p>10. Windows of a polycarbonate material are weather-sealed using gasketing and sealants.</p> <p>11. 3-Point high-strength door latches and door rods.</p> <p>12. Backup plate for ventilation openings.</p> <p>13. Storage box for replacement fuses.</p> <p>14. Self-latching door holder keeps door fixed open.</p> | <p>15. Gasketing around enclosure entry on outdoor units compresses against back of door when closed to prevent water entry.</p> <p>16. Sturdy internal screens provide a second barrier to shield against accidental contact and perforated to allow visual inspection.</p> <p>17. Door interlock prevents access to fuses unless switch is open.</p> <p>18. Sturdy operating handle with cast-aluminum housing includes provisions for padlocks and key interlocks.</p> |
|----------------------------------------------------------------------------------------------------------------------------------------------------------------------------------------------------------------------------------------------------------------------------------------------------------------------------------------------------------------------------------------------------------------------------------|---------------------------------------------------------------------------------------------------------------------------------------------------------------------------------------------------------------------------------------------------------------------------------------------------------------------------------------------------------------------------------------------------------------------------------------------------------------------------|

*Enclosure door is open to show internal screens with openings for viewing switch position and blown-fuse indicators.*

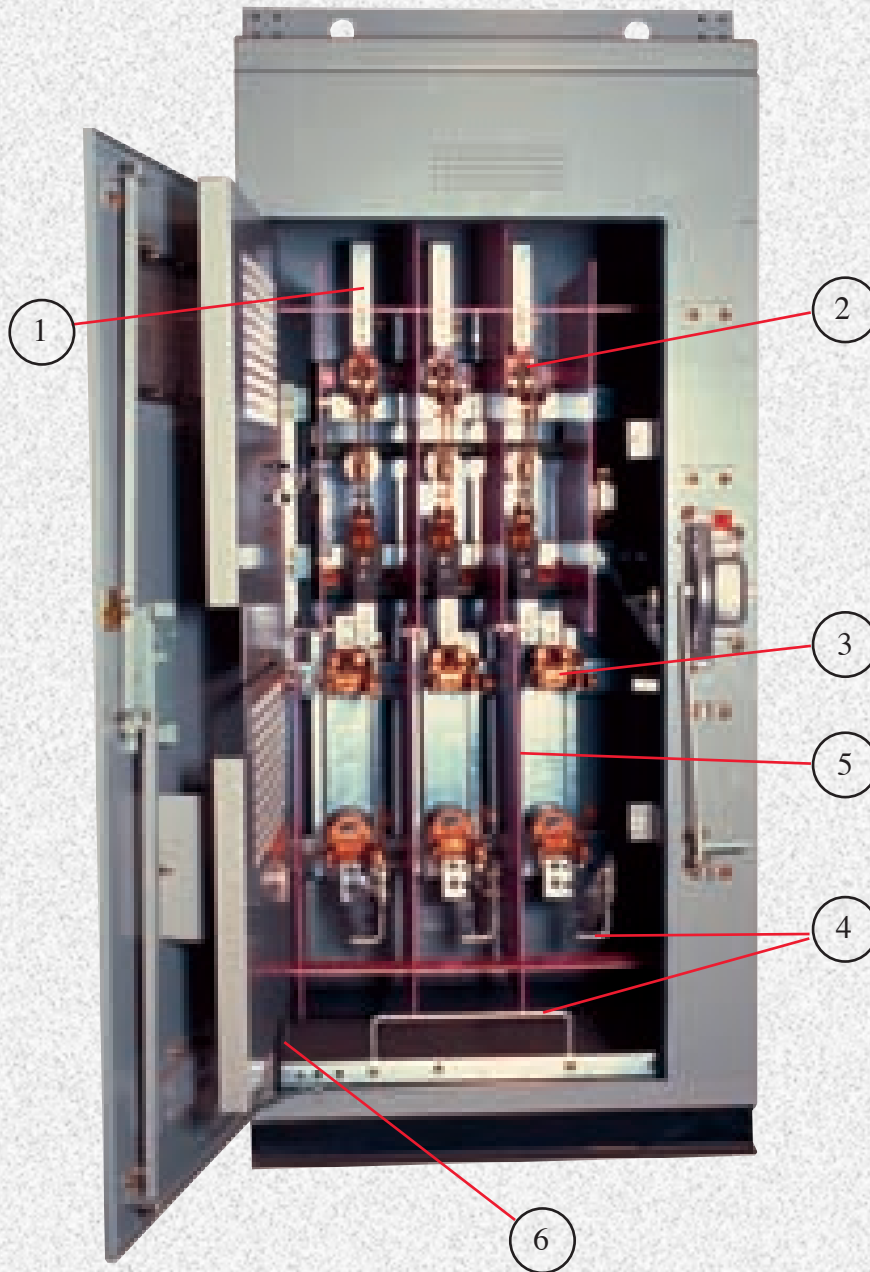

1. Main bus is rated for 600 amperes, 1200-ampere bus is also available.
2. Auto-Jet® load-interrupter switches, rated 600 and 1200 amperes, are UL® recognized and feature an industry-leading 3-time duty-cycle fault-closing rating of 40,000 amperes asymmetrical and a 1-time duty-cycle fault-closing rating of 61,000 amperes asymmetrical.
3. Unit can be furnished with a variety of power fuses which are current-limiting or expulsion fuses.
4. Ground studs on fuse terminal and provisions on ground bus.
5. GP0-3 fiberglass barriers isolate phases and ground plane.
6. Heater in fused circuit inside outdoor units (not visible on sidewall of enclosure).

*Door and screens open showing clear space for terminating cables and replacing fuses.*

## Features (Single-Bay & Multi-Bay)

- Standard doors are full height. Inner screen doors control access to fuses and other energized components.
- Metering transformers may be located in switch-fuse compartment or may be located in a separate adjacent compartment.
- Switch position can be seen through sealed, clear polycarbonate window and perforated inner screen.
- Bulkhead doors feature 3-point latching, a captive hex-head security bolt, padlockable flush mounted handle, self-latching door stop and stainless-steel concealed hinges. Category A security features are available as an option.
- Switch handles have provisions for padlocking in the opened or closed positions.
- Standard ventilation louvers are included at top and bottom on front and back of each bay. All louvers on outdoor assemblies are tamper resistant and have internal screens with filters.
- Mechanical interlock prevents opening door with switch closed or closing switch with door open.
- Bus bars are aluminum (copper optional).
- Ground bus in each compartment is aluminum (copper optional).
- Hinged inner steel door guards against contact with the switch and is perforated to allow view of switch blades.
- "Danger — High Voltage" signs are located on inside on screen doors.
- Rear access is not required except to accommodate special entrance requirements.
- Fuses may be current limiting or expulsion type with exhaust control devices.

## Outdoor Units (NEMA 3R)

- Roof weather sealed to enclosure.
- Adjacent bays are sealed to keep water out from between the double walls.
- Roof caps over joints between bays are provided as an added measure to exclude water.
- A space heater (on a fused circuit) in each unit eliminates excessive condensation.
- Externally removable filters provided with outdoor features.
- Formed steel channel base on each individual unit has an insulating coating applied.
- Underside of all roofs have a heavy coat of anti-condensation compound.

## Optional Features and Accessories

- Mimic Bus
- Single-Phase Protection
- Blown Fuse Indication
- Analog or Digital Customer Metering
- Utility Metering
- Drawout VTs or CPTs
- Grounding Blades on Switch
- Undervoltage Trip
- Overvoltage Trip
- NEMA 3R Enclosure
- UL Listing (5 and 15kV)
- Station, Intermediate and Distribution Class Surge Arresters
- Key Interlocks
- Operation Counter
- Motor Operator Switch
- Auxiliary Switches
- Special Terminators
- Roof Bushings
- Current Transformers
- Special Paint
- Special Enclosure Material (304 or 304L Stainless Steel)
- Close Coupling to Transformers, Existing Switchgear, or Retrofit



*Exterior of Switch/Fuse Bay With Category A Security Features*



*Open Door View of Switch/Fuse Bay Showing Internal Screen*

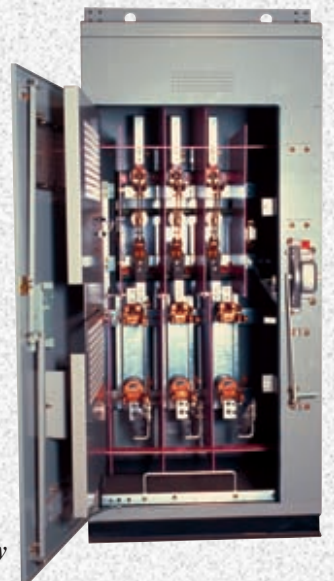

*Interior View of Switch/Fuse Bay*

# METAL-ENCLOSED SWITCHGEAR - CHECKLIST

## APPLICATION GUIDELINES

This checklist is an aid to establish the correct configuration of Metal-Enclosed Switchgear. This page can be used as a guide of what is to be furnished.

These pages contain information for defining the entire lineup and for setting the contents of each bay in the lineup. Insert in the space below each bay the cubicle number shown on "page 121". The cubicle number and the information in the Unit Requirements matrix will allow a clear understanding of what is to be furnished.

There are two basic Metal-Enclosed Switchgear arrangements. One is a single-bay transformer primary that is almost always used for a fused HV switch connected to a transformer, which can be either liquid filled or dry-type. It is suggested that this single cubicle be attached (closely coupled or throat connected) to the transformer to eliminate costly extra terminations and rear cable entry compartment needed for "bottom cable entry" and "bottom cable exit" in the same cubicle.

The second type of switchgear arrangement is a multi-bay lineup containing 2 or more cubicles. Within this type of arrangement there are several basic types of cubicles:

- Incoming** (sometimes fused)
- Feeder** (almost always fused)
- Transition** (main bus is redirected from a top routing to a bottom routing or vice versa)
- Metering** (includes current and voltage transformers)

Regarding cubicles with fuses, Federal Pacific recommends that current-limiting fuses be selected wherever possible for better energy limiting protection without the exhaust gases typically associated with expulsion fuses, whose pressures must be contained by the cubicle and whose arcing products may require cleaning of the inside of the cubicle after fuse operation. Cubicles with current-limiting fuses have a significantly lower initial cost than expulsion fuses.

For Incoming Cubicles connected to circuits at 15 kV that are above 400 continuous load amperes, Federal Pacific offers the choice of a metal-clad drawout vacuum circuit breaker that contains in a single module all of the CT's, relays, etc. necessary for operation, and which can be provided with a UL® listing in a standard 36" wide X 90" high cubicle or parallel arrangements of expulsion fuses, which require bays of up to 60 inches in width. Current-limiting fuses can be used in Incoming Cubicles at 5kV up to a continuous ampere rating of 1100 amps.

### Unit Requirements - Applies to the entire lineup

System Voltage: _____ Volts			
Fusing:	<input type="checkbox"/> Current Limiting	<input type="checkbox"/> Expulsion	
Enclosure:	<input type="checkbox"/> NEMA 1	<input type="checkbox"/> NEMA 3R	
Bus:	<input type="checkbox"/> Aluminum - Tinplate	<input type="checkbox"/> Copper - Silver Plate	<input type="checkbox"/> Other
Construction:	<input type="checkbox"/> Bolted	<input type="checkbox"/> Welded	<input type="checkbox"/> Other
Special Seismic Requirements:	<input type="checkbox"/> None <input type="checkbox"/> Zone 1 <input type="checkbox"/> Zone 2 <input type="checkbox"/> Zone 3 <input type="checkbox"/> Zone 4		
Category (Cabinet Security):	<input type="checkbox"/> A	<input type="checkbox"/> B	<input type="checkbox"/> C
UL® Listed:	<input type="checkbox"/> Yes	<input type="checkbox"/> No	
Finish:	<input type="checkbox"/> ANSI 61	<input type="checkbox"/> Other (Specify)	
Door:	<input type="checkbox"/> Flush Door Handle (Available with Category A only)		<input type="checkbox"/> Grip Handle Lever
Interlocks:	<input type="checkbox"/> Mechanical	<input type="checkbox"/> Key	
Utility-Type Metering Bay:	<input type="checkbox"/> Required	<input type="checkbox"/> Not Required	

Enter in space below each bay # at right applicable cubicle number from One-Line Diagrams on Page 119.

	Bay #1	Bay #2	Bay #3	Bay #4	Bay #5	Bay #6	Bay #7	Bay #8	Bay #9	Bay #10	Bay #11
Switch (Amps) for each cubicle											
Fuse (Amps) for each cubicle											
Bushings between Cubicles	(Y or N)										
LA _____ kV	(Y or N)										
<input type="checkbox"/> Dist. <input type="checkbox"/> Int. <input type="checkbox"/> Stat.											
Power Operated	(Y or N)										
Automatic Transfer	(Y or N)										
Stored Energy	(Y or N)										
Run & Trip	(Y or N)										
With SCADA	(Y or N)										
1-Phase Protection	(Y or N)										

## Typical One-Line Diagrams for Individual Bays of the Lineup Showing the Applicable Cubicle Number and Cubicle Description.

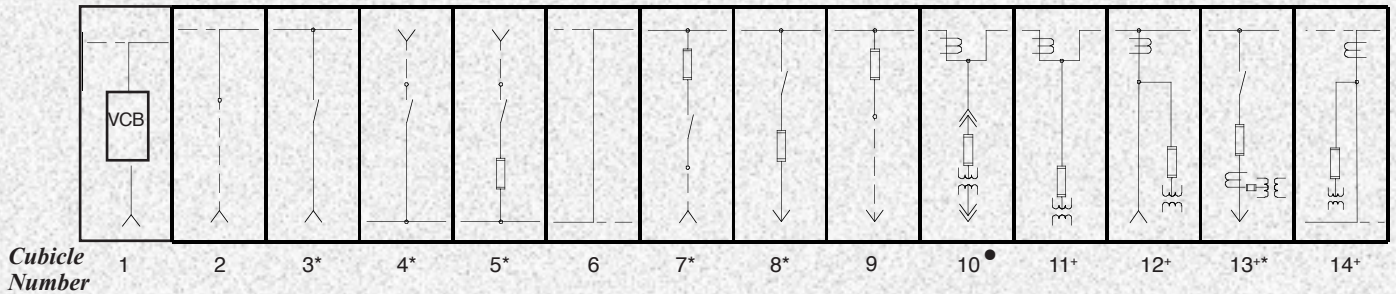

1. **Incoming Vacuum Circuit Breaker** for circuit protection at 15 kV of load currents greater than 400 A.
2. **Bus Entrance**, main bus top, provision for bottom entry.
3. **Switch Only**, main bus top, bottom cable entry.
4. **Switch Only**, main bus bottom, top cable entrance.
5. **Switch/Fuse**, main bus bottom, top cable entrance.
6. **Bus Transition**.
7. **Incoming Cubicle Switch/Fuse**, main bus top, bottom cable entry.
8. **Feeder Cubicle Switch/Fuse**, main bus top, bottom cable exit.
9. **Feeder Cubicle Fuse Only**, main bus top, bottom entry (or exit).
10. **Main-Bus Metering**, provisions for CTs and drawout fused PTs.
11. **Main-Bus Metering**, provisions for CTs and fixed fused PTs.
12. **Bus-Entrance Metering**, main bus top, provisions for CTs and fused PTs, bottom entry.
13. **Switch/Fuse Metering**, main bus top, provisions for CTs and fused PTs bottom exit.
14. **Bus-Transition Metering**, provisions for CTs and fused PTs.

## Typical Single Units

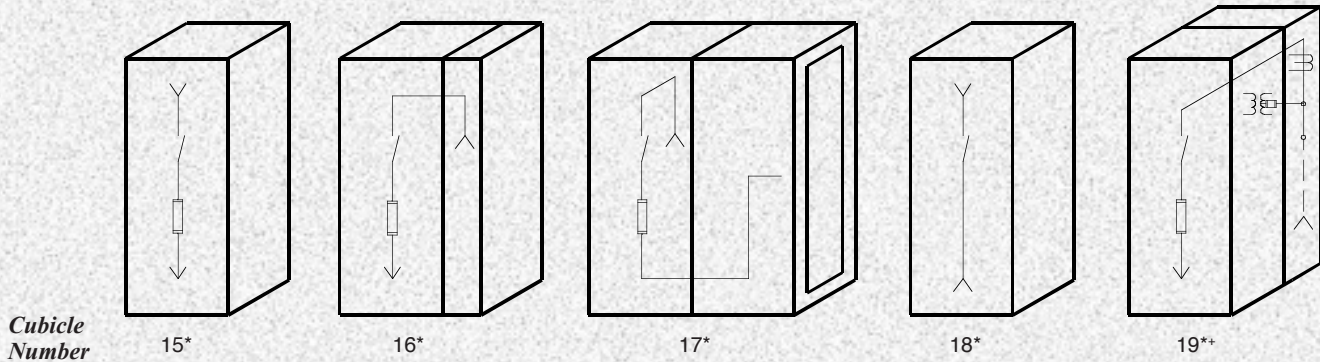

15. Switch/Fuse top cable entrance, bottom cable exit.
16. Switch/Fuse, bottom cable entrance on side, bottom cable exit.
17. Switch/Fuse with bottom rear cable entry and with transformer transition.
18. Switch Only, top cable entrance, bottom cable exit.
19. Switch/Fuse Metering, bottom rear cable entrance, bottom front cable exit.

## Component Standard Symbols

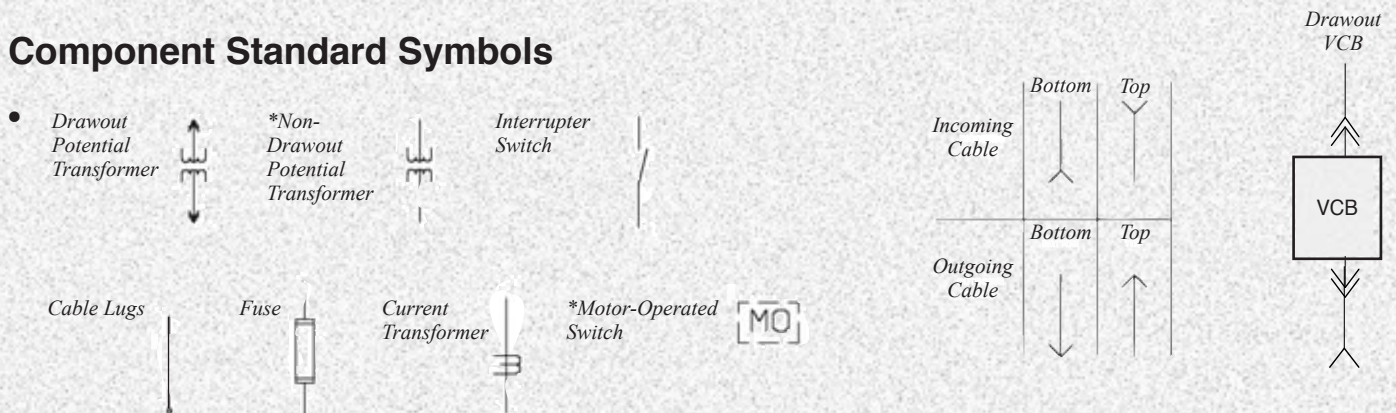

• +\* Typical units with corresponding footnote symbols can accommodate the associated components.

