

INSTRUCTION MANUAL

Metal-Enclosed Switchgear Indoor and Outdoor Distribution

2400 volts through 34,500 volts



Safety Information	2	Installing Strip Heaters.....	12
Introduction	3	Reinstalling Barriers	12
Receiving, Storing & Installation	4	Cleaning Before Testing & Energization	12
Receiving and Inspection.....	5	Dielectric Testing	12
Hoisting	5	Security Provisions	13
Storage	5	Enclosure Security.....	13
Installation	6	Access Control.....	13
Placement & Alignment of Cubicles.....	6	Gaining Access	14
Inter-Unit Bus Splices.....	8	Securing Doors, Covers & Panels	14
Grounding	9	Operational Testing	14
Removal of Temporary Items.....	9	After Operational Testing.....	15
Interlocks.....	9	Manual & Shunt-Trip Switch Operation	15
Check Switch Operation	10	Components and Accessories	16
Assemble Fuse Components.....	10	Interlocks	17
Cable Installation to Terminals	10	Maintenance	18
Installing Current Transformers	11	Warranty	19
Installing Arresters	12		

⚠ WARNING

The equipment covered by this publication must be selected for a specific application and it must be operated and maintained by qualified persons who are thoroughly trained and knowledgeable in the installation, operation, and maintenance of underground power distribution equipment along with the associated hazards that may be involved. This publication is written only for such qualified persons and is not intended to be a substitute for adequate training and experience in safety procedures for this type of equipment. Proper installation is the responsibility of the operating and construction personnel and the utility performing and authorizing the work. Completion of these instructions implies no further warranty by the manufacturer.

A qualified person is one who is trained and competent in:

- The skills and techniques necessary to distinguish exposed live parts from non-live parts of electrical equipment.
- The skills and techniques necessary to determine the proper approach distances corresponding to the voltages to which the qualified person will be exposed.
- The proper use of the special precautionary techniques, personal protective equipment, insulating and shielding materials, and insulated tools for working on or near exposed energized parts of electrical equipment.

These instructions are intended only for such qualified persons. They are not intended to be a substitute for adequate training and experience in safety procedures for this type of equipment.

SAFETY INFORMATION

Understanding Safety-Alert Messages

There are several types of safety-alert messages which may appear throughout this instruction bulletin as well as on labels attached to the pad-mounted switchgear. Familiarize yourself with these types of messages and the importance of the various signal words, as explained below.

DANGER

“DANGER” identifies the most serious and immediate hazards which will likely result in serious personal injury or death if instructions, including recommended precautions, are not followed.

WARNING

“WARNING” identifies hazards or unsafe practices which can result in serious personal injury or death if instructions, including recommended precautions, are not followed.

CAUTION

“CAUTION” identifies hazards or unsafe practices which can result in minor personal injury or product or property damage if instructions, including recommended precautions, are not followed.

NOTICE

“NOTICE” identifies important procedures or requirements that, if not followed, can result in product or property damage if instructions are not followed.

FOLLOWING SAFETY INSTRUCTIONS

NOTICE



Thoroughly and carefully read this instruction bulletin before installation of the metal-enclosed switchgear, before switching or operating the switches or fuse mountings in this equipment, and before performing any maintenance on the equipment.

If you do not understand any portion of this instruction bulletin and need assistance, contact Federal Pacific at 276-466-8200.

Replacement Instructions & Labels

If you need additional copies of this instruction bulletin, contact Federal Pacific at 276-466-8200.

It is important that any missing, damaged, or faded labels on the equipment be replaced immediately. Replacement labels are available by contacting Federal Pacific.

SAFETY PRECAUTION

DANGER

Federal Pacific Fuse Mountings in conjunction with appropriate fuses are designed to protect equipment and to disconnect faulted equipment from the system. The fuses cannot protect personnel from injury or electrocution if contact is made with energized circuits or hardware.

INTRODUCTION

DANGER

The Federal Pacific Medium Voltage Metal-Enclosed Switchgear products, covered within this publication, must be selected, installed, operated, and maintained by qualified persons who are thoroughly trained and who understand all possible hazards that may be present. This publication is written only for such qualified persons and is not intended to be a substitute for adequate education, training and experience in safety procedures for this type of medium voltage, Metal-Enclosed Switchgear.

Each assembly of Federal Pacific Metal-Enclosed Switchgear is provided with an "OPERATION AND MAINTENANCE MANUAL PACKET" located in the holder inside the switchgear bay door on which the label "OPERATION AND MAINTENANCE MANUAL PACKET Inside This Bay" is affixed. The "OPERATION AND MAINTENANCE MANUAL PACKET" includes applicable instruction sheets covering installation of the switchgear, assembly and operation of components, plus drawings and wiring diagrams. All personnel involved with installation and operation and maintenance of the switchgear assembly should be thoroughly familiar with the contents of the "OPERATION AND MAINTENANCE MANUAL PACKET".

This equipment has been provided with comprehensive access control and operating features to minimize hazards. However, since this equipment contains high voltage, there are hazards inherently present such that the following precautions should be observed at all times. **FAILURE TO OBSERVE THESE PRECAUTIONS MAY RESULT IN SERIOUS INJURY OR DEATH.**

1. Padlocks must be installed and secured on manual switch operating handles at all times unless the switch is being operated. Non-removable, manual handles in high-voltage compartment doors and hinged-pad lockable covers, as well as hinged-bolted panels, have provisions for padlocks which must be in place and secured at all times, unless work is being performed inside the enclosure.
2. **Key interlocks** must be in place. Prior to connecting the switchgear to the power circuits, check the operating sequence of key interlocks to verify proper sequencing. After the switchgear is installed, destroy all duplicate keys. **Key interlocks are not security locks.** The functional operation of key interlocks is illustrated on the drawings furnished with the switchgear. Refer also to "INTERLOCKS" on Page 17.
3. **Mechanical interlocks** are provided to prevent access to fuses, unless the switch is open and prevent opening the compartment door when the switch is closed. Mechanical interlocks prevent operation of stored-energy switch operators, when the enclosure door is open. **Do not attempt to operate any switch when the enclosure door is open.** Annually, verify that these mechanical interlocks are functional. Refer to the instructions under "INTERLOCKS" on Page 17.

4. When attempting to open or close a door or cover, do not apply any extreme force to any handle. The use of excessive force may damage the handle or latching mechanism, or jam an interlock mechanism. Do not attempt to close doors in an effort to reset interlocks. Always follow the instructions under "INTERLOCKS" on Page 17.
5. Precautionary signs and labels containing "CAUTION," "WARNING" or "DANGER", must not be removed or obscured.
6. When work is not being performed inside the enclosure, make sure that all hinged-bolted panels and doors are bolted closed and padlocked, if applicable.
7. Verify with proper instruments and meters that all switchgear enclosures are properly grounded.
8. Before performing inspection or replacement of components, make certain that fuses are disconnected from all power sources, including HV power cables connected to loads and fuses on instrument transformers which can be a source for back feed.
9. Before touching any device that is to be inspected, serviced, or repaired, test for voltage and install suitable and proven grounding equipment. All testing devices should be verified to be fully functional and operating properly before being used to test for voltage. Testing devices must be adequate for the voltage level of the switchgear equipment being checked.
10. Always assume both sets of power terminals on switch, fuse, or terminal connections **ARE** energized, unless proved otherwise by test and visual evidence.

DANGER

Energizing space heaters. If the space heaters are wired to be normally served through the secondary windings of voltage transformers (VTs or CPTs) located in the switchgear assembly, **do not** energize the space heaters from an external source, until the following precautionary measures have been taken: First, on the VTs disconnect the secondary leads and remove the secondary fuses. Remove the primary fuses from the VTs and space heaters. If secondary connections are disconnected, tape the ends of the leads to prevent inadvertent short circuits or contact with the transformer secondary terminals. Then connect the temporary external source to the space heaters. These precautionary measures must be taken to avoid energizing (back feeding) the switchgear conductors at high voltage through the voltage transformers, which could result in serious injury or death.

Even during storage always assume the cubicle bus is energized at rated service voltage unless proved otherwise by test using a testing device suitable for the voltage involved.

DANGER

Disconnect all potential sources of backfeed. Disconnect all voltage transformers (including PTs, voltage sensors and capacitor trip devices), when external voltage is used to test any secondary-side wiring or when heaters are energized from an external source for temporary storage. Do not disconnect any voltage transformers or voltage limiters, when the switchgear is energized.

and maintenance information regarding Federal Pacific Metal-Enclosed, Motor Operated Switchgear consult Federal Pacific Publication IB-3C-350.

“Instructions For Operation” of each Federal Pacific manufactured component are provided in separate Federal Pacific instruction sheets. For each switchgear assembly the applicable instruction sheets, drawings, and wiring diagrams are in an envelope entitled “OPERATION AND MAINTENANCE MANUAL PACKET”. This envelope is located in a holder inside the switchgear bay door marked “One Line Diagram”. When furnished by an Original Equipment Manufacturer, Instructions for components not of Federal Pacific manufacture are provided in the same door pocket as the OPERATING AND MAINTENANCE MANUAL PACKET.

RECEIVING, STORING AND INSTALLATION

The following instructions are for installation of Federal Pacific Metal-Enclosed Switchgear rated 2400 volts through 34,500 volts. This publication covers Manually Operated Switchgear containing many types of components, such as interrupter switches, power fuses, controls, potential transformers, current transformers, meters, etc., depending on user requirements. These components may be manufactured by Federal Pacific or by others. For additional important installation, operating

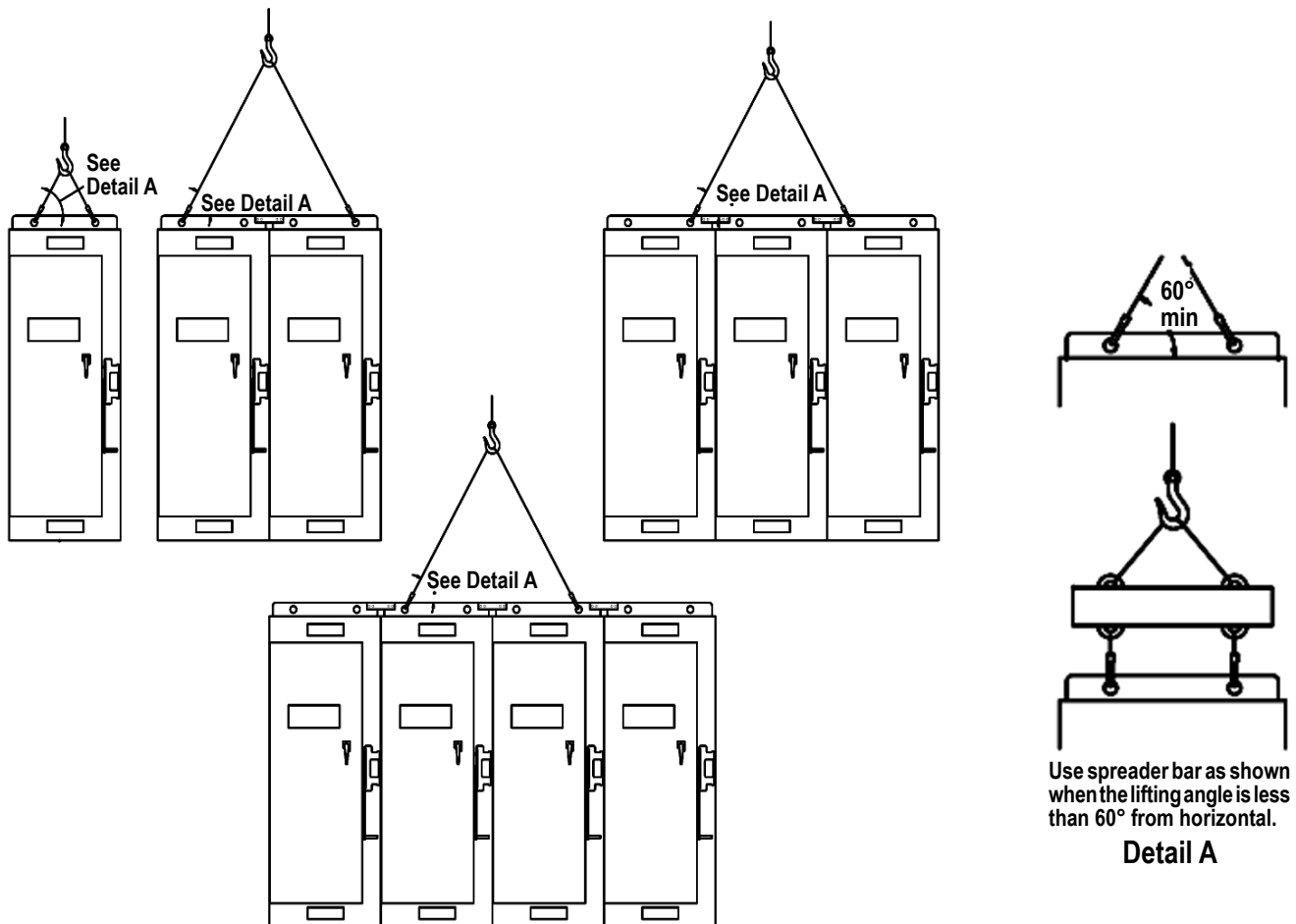

Figure 1. Hoisting arrangements for Federal Pacific Metal-Enclosed Switchgear.

RECEIVING AND INSPECTION

Receiving

For shipping Federal Pacific Metal-Enclosed Switchgear may or may not be fastened to wood skids as individual bays or multi-bay units in three or four cubicle sections, depending on the type of truck or trailer required.

If the Federal Pacific Metal-Enclosed Switchgear is fastened to a wood skid, it may be moved using a fork lift with suitable lifting capacity and proper fork spacing.

Certain items, such as fuse components, etc., may be packaged separately and, insofar as practicable, are shipped within the cubicle enclosures.

NOTICE

Examine the switchgear for external evidence of damage. If there is obvious shipping damage to any of the switchgear, immediately file the proper claim as described below with the shipper and notify the proper Federal Pacific representative.

Immediately upon arrival of the switchgear, carefully verify that you have received each component item on the shipping packing list (hardware, bus splice plates, fuses, etc.).

Missing items must be identified on the shipping papers before the delivering carrier departs from the shipping destination.

For Shipping Damage and/or Missing Items:

1. Notify the delivering carrier immediately.
2. Ask for a carrier inspection including pictures.
3. Note condition of shipment on all copies of the delivery receipt.
4. File a claim with the carrier

If concealed damage is discovered:

1. Notify the delivering carrier within 15 days of receipt of shipment.
2. Ask for a carrier inspection of the switchgear.
3. File a claim with the carrier.

Hoisting

WARNING

To avoid damaging the switchgear when handling with an overhead hoist, observe normal recommended procedures as well as the following general instructions.

1. Arrange hoist slings so as to distribute the lifting forces equally on all lifting holes. See Figure 1.
2. Do not apply lifting force to any lifting holes at an angle less than 60 degrees from the horizontal. See Detail A, Figure 1.
3. If it is not possible to adhere to Instruction 2 use a spreader bar as shown in Detail A, Figure 1.
4. Be sure the angle members containing the lifting holes on the enclosure are securely bolted down before lifting the gear.
5. Avoid sudden starts and stops by the crane.
6. NOTE: It is not necessary to remove the lifting angles after the switchgear has been installed. If the angle members containing the lifting holes are removed the bolts must be replaced and sealed to prevent water from entering the cabinet.

Storage

Federal Pacific Metal-Enclosed Switchgear should preferably be installed in its permanent location immediately. The space heaters for outdoor switchgear (and indoor switchgear if so equipped) should be activated at once, (see "Danger Energizing Space Heaters" on Page 2, below point 10) even though the switchgear itself is not to be energized until later. See Figure 2. This storage requirement is especially important for bays containing meters and relays, which are particularly susceptible to damage from moisture.



Figure 2. Strip heater is mounted behind a perforated sheath on side wall of enclosure.

INSTALLATION

CAUTION

If the switchgear cannot be installed immediately, store in a clean, warm, dry room, especially indoor switchgear. The switchgear cubicles should be protected against condensation, dust, and physical damage.

If **Outdoor Storage** is a necessity, the following precautions must be taken:

Indoor Switchgear

If the switchgear were shipped with an outer protective wrapping, this covering should be removed. Provide shelter for the switchgear with a tent-like covering to allow adequate ventilation and prevent the entry of rain, snow, and contaminants. If the switchgear is not equipped with space heaters, install temporary electric heaters (at least 250 watts per bay) to promote circulation to keep the interior dry.

Outdoor Switchgear

If the switchgear were shipped with an outer protective wrapping, this covering should be removed. Shelter the switchgear as described in the previous section for **Indoor Switchgear**. If the switchgear is to be stored for a considerable time (more than one week), connect and energize the space heaters to minimize condensation. See "**DANGER-Energizing Space Heaters**" on Page 2, below item 10.

If the switchgear is to be stored, and it is impossible to connect and energize space heaters or temporary heaters, remove all meters, whether installed or separately boxed, and store the meters in a clean, dry room. Cover all openings to the interior.

Switchgear With Batteries

If the switchgear includes batteries, additional storage requirements apply. The battery charger should be disconnected from the battery; the battery should be charged periodically to avoid deep discharge that would damage the battery; and the battery should be charged for 24 hours following any extended storage beyond 4 weeks.

Placement & Alignment of Cubicle(s):

Step 1 - Transport the switchgear to the installation site observing the precautions given under the "**HOISTING**" section in Figure 1.

Step 2 - At the installation site, remove all the separately packaged components which were shipped within the enclosure and set them aside in a protected area.

Step 3 - Each bay of a multi-bay assembly is identified by a number on the front of the bay. Proper positioning of the switchgear is indicated by corresponding numbers on the anchor-bolt plan shown in Figure 3(a) and shown in the drawing enclosed in the waterproof envelope labeled: "**OPERATION AND MAINTENANCE MANUAL PACKET**".

On multi-bay assemblies shipped together as individual units consisting of bays, or groups of bays, the unit whose working clearance will be most affected by adjacent walls or structures should be placed first.

With all shipping skids removed lift the unit over the anchor bolts, observing the precautions given under "**HOISTING**" in Figure 1. Align the channel base so that it is square with and centered around the rectangular anchor bolt pattern shown in Figure 3(a).

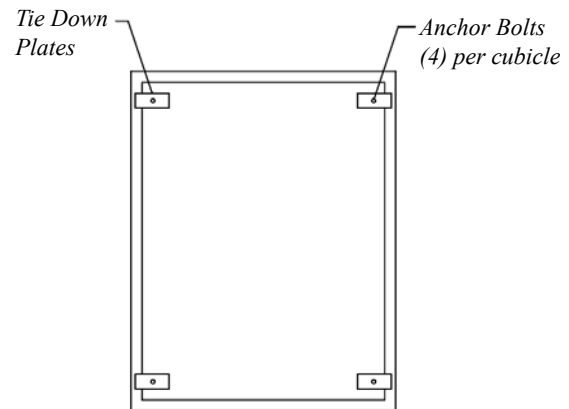

Figure 3(a). Anchor-bolt and tie-down plate locations. Align level and shim bays so that holes between bays are in alignment.

Where power and control cables are to enter the enclosure through trench or conduit in the mounting pad, **check** these locations for alignment with the terminating pads provided in the switchgear cubicles and with control wire entry locations, as applicable.

If excess lengths of direct-buried cable are in place and it is desired to feed them into the bay as the unit is being lowered, the doors may be opened (with door holders latched) to allow any excess cable to be fed over the door sills. It should not be necessary to remove any end barriers. Terminating of cables is discussed under "**Cable Installation to Terminals**" on Page 10.

Step 4 - On indoor assemblies furnished with optional drip-proof or dust proof construction and on outdoor multi-bay assemblies, be sure to obtain a weather-tight seal between cubicles. To achieve the proper seal Federal Pacific recommends using GE Silicone Sealant, #GE108, for making **ALL** cubicle surface joints.

On Federal Pacific **outdoor** switchgear a suitable outdoor caulk (Sealant #GE108) should be applied to seal the surfaces between the cubicles. For the roof seal Federal Pacific uses a roof cap channel design with a gasket (furnished) to prevent water from entering into the connecting bus area. See Figure 5).

Step 5 - Following the correct concept in Figure 4, level the base, using metal shims as required. Secure each bay to the pad with the anchor clips ("hold down plates") provided, (see Figure 3a and Figure 3b) by tightening the anchor-bolt nuts.

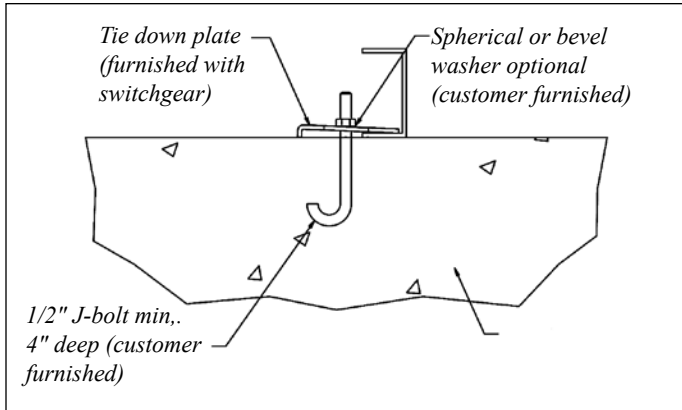

Figure 3b. Anchor Bolt Detail.

After tightening the anchor-bolt nuts, make sure that the switchgear-bay doors open and close without binding. Binding indicates enclosure distortion which must be corrected by additional shimming.

Apply grout at the bottom of the enclosure to prevent entry of rodents, insects, or weeds. On outdoor assemblies, the grouting should be recessed sufficiently from the exterior exposure to permit caulking with a weatherproof compound, applied with a standard caulking gun. A room temperature vulcanizing (RTV) silicone rubber compound is recommended.

On multi-bay assemblies shipped in individual units, align, level, anchor, check door operation, grout, and caulk succeeding units in turn. Join units with the 3/8"-16 bolts. See Figure 3c and Figure 4.

Do not attempt to draw misaligned units together with these bolts. See Figure 4. On multi-bay assemblies, avoid misalignment which may result in improper operation of the switchgear and avoid ineffective weather sealing between bays. Before installing the switchgear, determine where shimming will be necessary, and have the required shims on hand. Using proper tools make sure that all sides of the switchgear are completely vertical.

Shims for leveling components may be aluminum, copper, or copper alloy. Shims should not be material subject to corrosion or decay.



Figure 3c. Draw edges of bus openings together, if necessary.

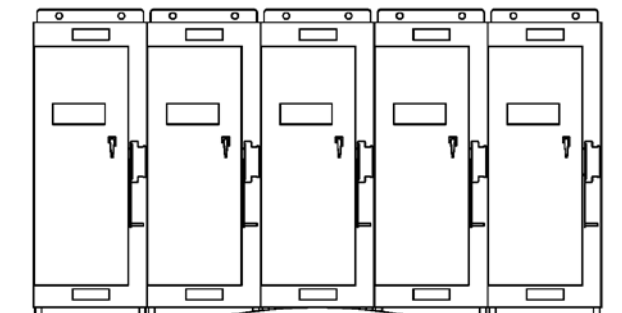

This!

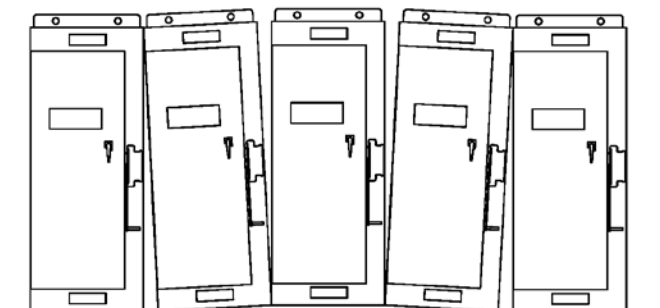

Not This!

Figure 4. Alignment of multi-bay switchgear assemblies.

Step 6 - On outdoor switchgear, after all bays are in place and bolted together, install roof caps and gaskets (furnished) over roof flanges (See Figure 5) between bays and bolt in place using the hardware furnished. Using an outdoor rated caulk, #GE108, caulk the vertical edges between adjacent cubicles. It is not necessary to caulk the metal surfaces between the roof cap hardware and the roof cap gasket. Install and tighten bolts and nuts at edges of through-bus openings on adjacent bays using the hardware furnished.

Step 7 - Remove shipping braces installed to restrain movement of these parts during shipping and handling.

Inter-Unit Bus Splices

Step 8 - Bus and terminal connections are typically copper-to-copper, aluminum-to-aluminum or aluminum-to-copper. Federal Pacific furnishes all hardware including 2 Belleville washers for each bolt.

See Figure 6, on Federal Pacific switchgear where "shipping split" connections are found, these bus connections also employ Belleville washers. Connecting bolts have been torqued to 50 foot-pounds.

Terminal pads on Federal Pacific Metal-Enclosed Switchgear Indoor and Outdoor Distribution (2400 volts through 34,500 volts) may be aluminum or copper whose connections employ Belleville washers. Unless they are visibly loose, factory-made connections, using Belleville washers torqued to 50 foot-pounds do not require retightening. Make some "spot checks" to verify correct tightness.

Step 9 - For the inter-unit splices in the main bus and ground bus runs, splice-plate kits have been provided. These kits contain splice plates, bolts, nuts, and washers.

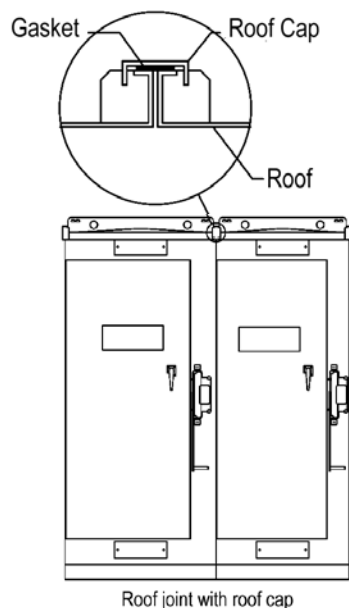

Figure 5. Installation of roof caps over roof flanges on outdoor switchgear.

For aluminum bus, both the bus ends and splice plates have been pre-abraded and coated with a thin layer of oxidation inhibiting grease at the factory.

To ensure the highest quality joints, the mating surfaces of aluminum bus ends and splice plates should be re-abraded and immediately coated with a uniform layer of Noalox just prior to making the bolted connections.

CAUTION

For copper main bus and ground bus, joint surfaces may be silver-plated or tin-plated and require no corrosion-inhibiting compounds. Therefore, before joining, simply clean the surfaces with a clean dry cloth, or if necessary, with a mineral spirits solvent. **Do not use abrasives** of any kind to attempt to remove discoloration, which may appear on the silver-plated surfaces. This discoloration is characteristic of silver and does not affect the performance of the bus splice.

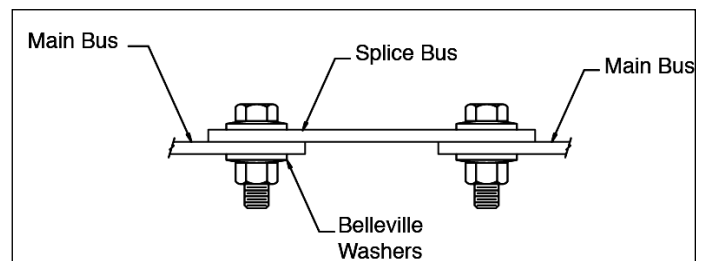

Figure 6. Installation of Inter-unit bus splices.

Refer also to Figures 6 and 7, for installing hardware between cubicle bus splice plates:

Place the splice plate on the **top** of the ends of main bus sections, or on the **side** of the ground bus that faces the exterior of the bay. Make up the main bus connections using one Belleville washer under the head of each bolt and one Belleville washer under each nut.

The bolts **must** be installed with the bolt head on the top side of the main bus. Belleville washers **must** be installed with the larger outer ring of the cup toward the bus. See Figures 6 and 7. Tighten all splice bolts and nuts to a torque of 50 foot-pounds as indicated by a torque wrench. If a torque wrench is not available, tighten until the Belleville washers are flat, and then back off one half turn.

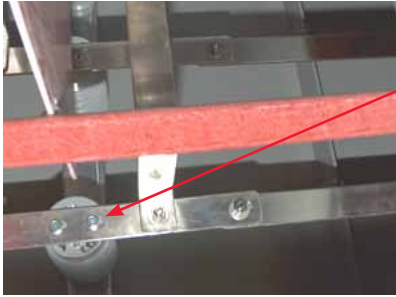

Figure 7. If one or two Belleville washers are used with the hardware supplied, tighten to 50 foot-pounds.

In the case where "through bushings" are used between cubicles (see Figure 8), the cubicles should be aligned to permit the "through bushings", attached to the one cubicle to enter the adjacent cubicle through the rectangular opening in the side of the adjacent cubicle. The two cubicles should be bolted together in the same manner as adjacent cubicles without through bushings. After the cubicles are bolted together, the remaining bus connections will be bolted and torqued as described above.

Grounding

Step 10 - Make up ground connections from the ground bus (or ground pad on a single-bay assembly) to the permanent station or system ground facility. It is recommended that cable not smaller than # 1/0 copper, or equivalent, be used, and if the maximum momentary rating of the switchgear is to be realized, the equivalent of 500 MCM of copper cable is required in either a single or multiple connection.



Figure 8. Through Bushings

Step 11- If secondary and control wiring is present, all terminals should be checked for tightness. Also, connect secondary and control wiring between adjacent bays at points where "shipping splits" occur. The individual wires at terminal blocks are marked to correspond with the adjacent terminal-block marking. Connection of the secondary and control wiring should be checked with reference to the applicable wiring diagram included with the "OPERATION AND MAINTENANCE MANUAL PACKET". If connector plugs and receptacles are used in lieu of terminal blocks at points where "shipping splits" occur, connect the mating plugs and receptacles.

Removal of Temporary Items

Step 12- Remove all temporary jumpers that have been connected across the current-transformer secondary and remove all current-transformer shorting screws from the shorting-type terminal blocks. Remove all shipping braces not previously removed.

Step 13 - Remove all restraining tapes and blocking from the movable elements of the meters and relays (if included), used to prevent movement of these parts during shipment, and check the elements for freedom of movement.

⚠ NOTICE

Relays are not set at the factory and, therefore, must be adjusted by the user to the proper setting.

⚠ DANGER

Failure to remove shipping braces, temporary items such as jumpers and shorting screws, and to properly set relays may result in equipment malfunction that may result in equipment damage, personal injury or death.

Check Interlocks

Step 14 - Switch operators and manual operating handles may be equipped with key and/or mechanical interlocks which, for example, guard against switch operation when the door of the bay containing the interrupter switch is open. Check functional operation of mechanically interlocked doors and switch-operating mechanisms. Refer to "Interlocks" on Page 17.

⚠ DANGER

Failure to check and adjust interlocks may result in personal injury or death.

Check Switch Operation

⚠ WARNING

To avoid personal injury or damage to interlocks, before operating any switches, close and latch the associated door, and verify that switch operation is in the sequence dictated by the key or mechanical-interlock scheme provided. Before proceeding with these instructions, refer to "INTERLOCKS" on Page 17.

Step 15- Check operation of manually operated switches. Separate instruction sheets on manually operated interrupter switches are included in the "OPERATION AND MAINTENANCE MANUAL PACKET" provided with the switchgear.

If the switchgear is power-operated, the switch operators and automatic control equipment may now be checked. Separate instruction sheets for the switch operator(s) and for the source-transfer control are included in the "OPERATION AND MAINTENANCE MANUAL PACKET" provided with the switchgear and in Instruction IB-3C-350.



If high-voltage AC dielectric tests are to be performed on this switchgear, or if preliminary operational tests using an auxiliary control voltage source are to be performed before the switchgear is energized, special precautionary measures must be taken to prevent damage to certain switchgear components (such as current-transformers and surge arresters) or inadvertent energization of the switchgear main bus. Refer to section on "Dielectric Testing" on Page 12.

Assemble Fuse Components

Step 16 - Fuse components (such as holders, fuse units, end fittings, interrupting modules, etc.) are crated separately. Assemble these components following the fusing procedure described in the instruction sheet packed with the applicable fuse components. Install the fuses in the fuse mountings following the procedures described in the manufacturer's instruction sheet on operation, which is included with the switchgear, for the particular fuse type being used.

CAUTION

When installing fuses, make certain that complete fuse closure is attained. Store spare refill units, interrupting modules, or fuse units in the container mounted on the inside of doors to bays containing fuses or fused voltage transformers

Cable Installation to Terminals

Step 17 - After all other connections have been completed and checked, make up the medium-voltage cable terminations, following the cable terminator manufacturer's instructions.

If necessary, remove inter-phase barriers to facilitate makeup and connection of cable terminations to switch, fuse, or bus terminals. If the interphase insulating barriers are removed, note their positions to ensure correct reinstallation later.

For switchgear equipped with reverse-cable entrance or exit, the medium voltage cable must be installed inside the reverse cable bracket or pvc conduit. The "reverse-cable" arrangement allows both incoming and outgoing cables to enter the cubicle from the bottom or both cables to enter the cubicle from the top without having to employ a separate termination cabinet.

The reverse-cable bracket, when required, if furnished by Federal Pacific is in the form of PVC conduit, 4 inches in diameter, to permit up to 3-250MCM copper cables (approximately 300 amps continuous-max) for connection to the top of the Auto-Jet® switch.

Where field assembled types of cable-terminating devices are used, terminations must incorporate adequate leakage distance between the exposed conductor and the stress relief cone, across a surface of non-tracking material (or a surface rendered non-tracking by properly taping with a suitable material). Furthermore, to maintain the rated BIL capability of the switchgear, the required minimum clearances from energized parts (including unshielded portions of cable, such as terminator skirts) are as shown in Table 1 below.

WARNING

Failure to maintain the minimum electrical clearances shown in Table 1 below may result in personal injury or damage to equipment.

Step 18 - Following the user's established system operating safety procedures, check to make certain that connections of the incoming power source(s) to the switchgear terminals are in the proper phase sequence.

CAUTION

When making connections, care must be used to avoid placing any intentional strain upon any switch or fuse terminal. It is important that each cable terminator connector be flat against the corresponding switch or fuse terminal pad, with the bolt holes in alignment.

Do not use the connecting bolts to pull the cables into alignment. Failure to comply with these precautions may cause misalignment of the switch or fuse and result in equipment damage.

Nominal Volts in kV	Line-to-Line (Max Volts in kV)	BIL	Minimum Clearances (In Inches) Design Tested							
			Uninsulated Conductor		Insulation Barrier Air Gap Distance To			Insulated Conductor Air Gap Distance To		
			Line-to-Line	Line-to-Ground	Live Part	Insulator	Ground	Live Part	Insulated Bus	Ground
0.6	0.6	4	1.0	1.0	1.0	0.25	0.25	0.25	.025	0.25
4.8	5.5	60	3.5	3.5	3.5	0.5	.05	2.5	1.5	2.25
13.8	17	95	5.5	5.5	5.5	1.0	1.0	4.5	3.5	4.25
25.0	27/29	125	7.5	7.5	7.5	1.25	1.25	6.75	4.5	6.0
34.5/19.9	38.2/21.9	125	7.5	7.5	7.5	1.5	1.5	6.75	4.5	6.0
34.5	38	150	10.0	10.0	3.0	2.0	2.0	8.5	6.5	8.0

Table 1. Minimum Clearances in Air.

⚠ CAUTION

Before connecting the cable terminators to the terminal pads, thoroughly wire-brush aluminum contact surfaces to remove any dirt or foreign materials as well as the natural surface oxides. Immediately coat both contact surfaces, to one-half inch beyond the joint, with a uniform layer of Naolox.

Copper terminals have a thin layer of silver applied to contact surfaces and the terminal surfaces must be prepared as described in the "CAUTION" of Step 9 on Page 8.

Failure to properly clean and prepare connections can result in equipment damage.

Make up the connections as described in the following paragraphs (Refer to Figure 9).

⚠ NOTICE

Torque values apply only to the bus hardware described and not to connectors used to secure primary leads of voltage transformers or surge arresters to the bus.

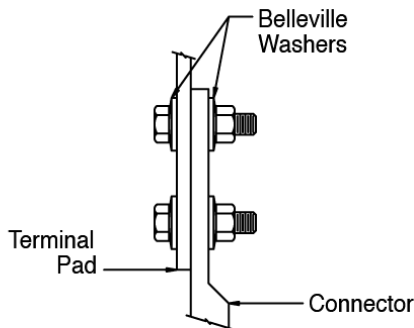

Figure 9. Terminal pad connections. Federal Pacific recommends that all terminal connections be made using Bellville washers.

⚠ CAUTION

After attaching the cable terminals to the terminal pads, to maintain the short-circuit rating of the switchgear assembly, secure the cable to the cable support bracket, which is provided in all bays where the available vertical cable space exceeds 24 inches for 4.16 kv, 30 inches for 13.8 kv, 36 inches for 25 kv, or 48 inches for 34.5 kv. Under momentary conditions, mechanical stresses caused by unsecured cables may damage switches and fuses.

Installing Current Transformers

Step 19- Switchgear may be equipped with Current Transformers having relay accuracy. On Metal-Enclosed switchgear where Federal Pacific supplies an optional overcurrent lockout feature controlled by the Federal Pacific OCS Controller, usually 600 volt class window type CT's will also be supplied. Federal Pacific will offer a "bracket-supported" window type CT or a "split core" CT as shown in Figure 10. The "split core" type CT is usually supported on the cable with heavy-duty tie wraps.

⚠ CAUTION

For correct functioning of the automatic control equipment, the current transformers (CTs) or current sensors must be located (around the cable and the concentric neutral ground wires of the cable) in a manner such that any current in the ground wires and cable jacket will be cancelled as it passes through the window of the CT. This can be accomplished by allowing the ground wire to pass through the CT window in one direction and return through the CT window in the opposite direction before being grounded (see Figure 10). This same statement applies to a "drain wire" coming from the bottom of the terminator through CT window mounted above the ending of the concentric neutral wires of the HV cable.

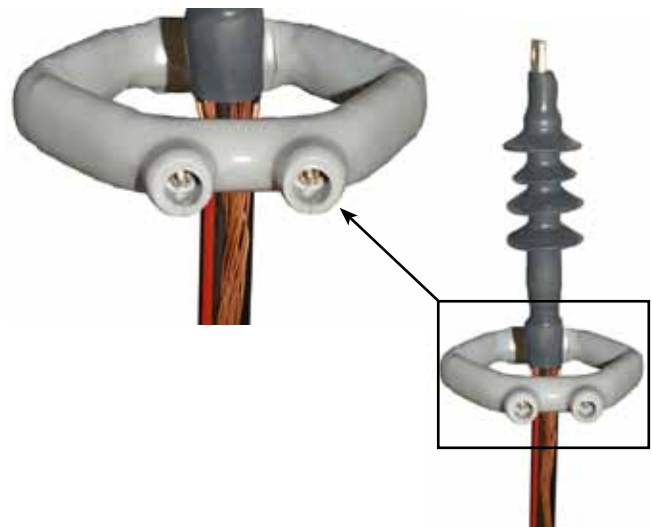

Figure 10. Current sensors are to be secured to conductor using heavy tie wraps. Note that concentric neutral is insulated (in cable) and passes back through current sensor as bare wire before connection to ground.



Installing Arresters

Step 20 - Install and connect surge arresters, if applicable.

Surge arresters must be selected and installed in accordance with the arrester manufacturer's application information and instructions. If surge arresters were installed by Federal Pacific, check all connections for tightness to make certain they have not worked loose during shipment.

Installing Strip Heaters

Step 21 - Strip heaters are included as standard in all Federal Pacific Metal-Enclosed Switchgear designed for outdoor installation, and may be provided as an option in indoor switchgear.

Therefore, when strip heaters are included, make sure that they are connected to an adequate power source.

DANGER

Prior to energizing strip heaters from an external source read carefully and understand all of the instructions to prevent dangerous "backfeeds" contained under "Danger - Energizing Space Heaters" under Item 10 on Page 3.

Reinstall Barriers

Step 22 - If any interphase insulating barriers were removed to facilitate accomplishment of the preceding steps, reinstall them at this time. Take care not to damage barriers on installation and make certain they are installed in the locations from which they were removed. Make sure that the clearances between barriers and energized parts conform to the minimum dimensions specified in Table 1 on Page 10.

Cleaning Before Testing & Energization

Step 23 - Sweep or vacuum floors of enclosures to be free of debris. Wipe barriers, insulators, bushings, terminators, switches, and fuses with a suitable mineral spirits solutions and dry with a clean dry cloth.

Step 24 - Check functional operation of key and mechanical interlocks, if furnished.

WARNING

To maintain the integrity of key interlock schemes, duplicate keys must be destroyed.

Step 25 - Remove from insulators, terminators, vents, bushings, switches, and fuses all shipping tape, "Temporary" labels, and polyethylene wrapping. Clean up any remaining adhesive.

Wipe down the exterior of the switchgear with a clean damp cloth and, when thoroughly dry, touch up any scratches and abrasions.

Before Walking Away

1. Check the interior of each bay for foreign materials, tools, etc., that may have been mislaid on high voltage bus and supporting members.
2. Make certain that motor switch operators, if furnished, are coupled to interrupter switches.
3. Make certain that all selector switches on source-transfer controls, if furnished, are in the desired positions.
4. Check all fuses to make certain they are completely seated and latched.
5. Close and securely latch all switchgear bay doors.
6. Make certain that all interrupter switches are in the correct positions, open or closed, as dictated by electrical system design.
7. Make certain that all "live part" grounding means have been removed.
8. Padlock all door handles, switch operating handles, and covers (if applicable).

Additional instructions on correct positioning of specific components for normal operation are contained in the Federal Pacific instruction sheet for the particular component. For such instructions, refer to the "OPERATION AND MAINTENANCE MANUAL PACKET" provided with the switchgear.

Dielectric Testing

For the convenience of users who normally perform electrical tests on system components, appropriate withstand test values are given in Table 2.

Table 2. Insulation Test Values ①

Rating, kV				Withstand kV		
System		Applied Line-to-Ground		60-Hz RMS	Dc	Impulse (BIL)
Nom.	Max.	Nom.	Max.			
4.16	4.8	2.4	2.77	19	27	60
14.4	17	8.3	9.8	36	50	95
25	27	14.4	16.7	60	70	125
34.5	38	19.9	21.9	80	—	150

① No more than 75% of the Withstand Values shown should be applied on switchgear after shipment from the factory.

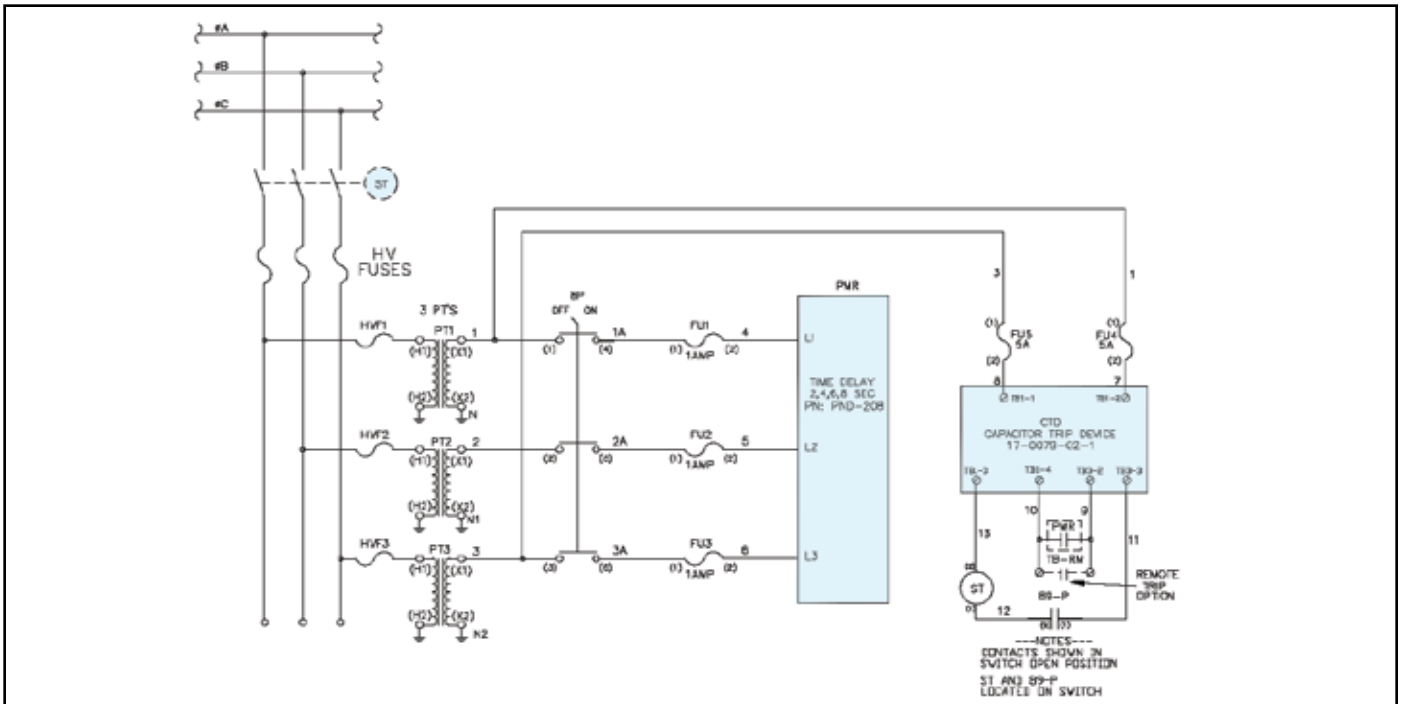

Figure 12. Electrical Schematic — Shunt-Trip.

⚠ DANGER

Before performing dielectric test ON THE SWITCHGEAR, make certain that the high-voltage cables and conductors are not connected (i.e., are de-energized and properly isolated and grounded). Test for voltage, and isolate and tag all circuits in accordance with established system operating safety procedures. In addition, remove the primary fuses and disconnect all secondary connections from all voltage transformers. Disconnect all surge arresters. Short out all CT output terminals.

If Switch with Shunt Trip is furnished, (1) Turn the toggle switch to the Shunt Trip circuit to "Off". Remove the fuses to the capacitor trip device (CPD). See Figure 11 and 12.

These precautions should also be followed when performing high-voltage DC dielectric tests.

ON/OFF Switch for Shunt Trip Capacitor



Figure 11. Shunt-Trip Switch Control Components.

After Dielectric Testing

After all tests have been completed, remove the CT shorting screws.

It is recommended that voltage-transformer primary fuses not be reinstalled - nor secondary connections of unfused voltage transformers reconnected until just prior to final energization of the switchgear for service. Remove all grounds connected to medium voltage terminals and reconnect all high voltage conductors and surge arresters.

SECURITY PROVISIONS

Enclosure Security

The Federal Pacific Metal-Enclosed Switchgear incorporates many provisions to minimize hazards to qualified persons and to the general public. Category A and Category B are both available. Each bay is fabricated from 11-gauge steel sheet and is a free-standing, self supporting unit. With this unitized design, there are always double walls between the adjoining bays.

Provisions for future bus extension are closed with a panel that is secured internally. Unless specified, access is from the front only, through doors having concealed cam-type, high strength latches that seal the doors shut. All doors and switch operating handles are pad lockable.

Access Control

Switch operators and controls are isolated from high voltage in grounded, metal-enclosed compartments. Access to these components is controlled by padlockable covers. Other low-voltage components, such as meters, selector switches, toggle switches, etc., are similarly isolated.

Key interlocks (where furnished), mechanical interlocks and padlocks help control access to high-voltage compartments.

A protective, punched screen door is furnished behind the outer doors that provide access to high-voltage components. These screens, when bolted closed, act as a second barrier to guard against inadvertent entry. Switch-operating handles are pad lockable in the **open** or **closed** position. On outdoor style switchgear, baffles and screens mounted inside the enclosure cover all vents, to discourage wire poking.

Since switchgear is often located in areas accessible to the general public as well as authorized but unqualified persons, care must be taken to alert such persons to the presence of high voltage within the enclosure. Therefore, do not remove any of the "Danger High Voltage — Keep Out" or "Danger — Hazardous Voltage" signs that have been attached to the switchgear. Any organization altering or removing these hazard-alerting signs must assume full consequences for such actions.

Take particular care to be sure that all screens and hinged-bolted panels are bolted **closed** and that all doors, handles, and covers are securely padlocked before leaving the switchgear **unattended** even momentarily.

Gaining Access

Access to the interior of the switchgear bays can be obtained through two types of entranceways: **high-voltage compartment doors** or **bolted panels**. For Category A construction hinged-pad lockable control cabinet covers control access to switch operators or other low voltage components.

WARNING

Do not apply excessive force to any door handle, when attempting to open a door. The use of excessive force may damage the door handle and latching mechanism. Excessive force may jam an interlock. Verify that opening the door is in the sequence dictated by the interlock scheme provided.

High-voltage compartment doors and hinged pad-lockable covers employ non-removable, pad lockable manual handles which pivot for door and cover opening. Most high-voltage compartment doors are secured closed by a padlockable three-point latching mechanism and a mechanical interlock.

If the cubicle bay includes fuses, a mechanical interlock is provided so that the associated switch must be opened before the cubicle door can be opened. When door is open this mechanical interlock is designed to prevent movement of the switch handle into the closed (up position). **Do not operate switches, unless its associated door is closed.**

To open the high-voltage cubicle compartment door (Category A) or hinged-pad lockable cover:

1. Remove the padlock from the hasp.
2. Loosen the penta-head bolt (Penta-head socket wrench supplied).
3. Firmly pull outward and downward on the "paddle" handle. To open a Category B cubicle door, start with number 1 above and then turn the door handle "counter-clockwise".

Hinged-bolted panels on switchgear bays or bus ducts may include captive bolts, key-operated interlocks and provisions for padlocks. To open these panels, remove the padlock and follow the prescribed sequence for unlocking the keyed interlocks.

Securing Doors, Covers and Panels

High-voltage compartment doors and covers are closed as follows. For doors, release the door holder at the bottom of the door. Then, push doors or covers fully closed. While holding the door or cover closed, rotate the door handle to engage the latches. Pull outward on the edge of the door (or cover) to verify that it has latched securely. A padlock should then be inserted into every hasp before the switchgear is energized.

Bolted panels are secured by positioning the panel and then tightening all bolts. Verify that the panel is correctly positioned, fully closed and bolted.

OPERATIONAL TESTING

If it will be significant time before high voltage is connected to the switchgear, the user may wish to perform a preliminary checkout of operational devices so as to expedite to "full-service-readiness" once high voltage is available. Operation of source-transfer controls and switch operators may be checked using an auxiliary control voltage source equal to the required voltage of the component subject to the following warnings.

DANGER

The voltage transformers (PTs and CPTs) must be **disconnected** on the low-voltage side when external voltage is used to test alternating current, powered switch operators and source-transfer controls, to avoid energizing the high voltage bus and conductors through the voltage transformers. Failure to do so may result in serious injury or death.

If the switchgear is equipped with the Federal Pacific OCS Controller, relays, and single phasing protection devices, instructions for preliminary operational testing are contained in the component manufacturers' books.

CAUTION
 Spring Energy is produced as the switch operating handle is rotated. Therefore, care should be exercised to insure that complete handle rotation is accomplished to either the maximum downward or maximum upward position.

DANGER
 To prevent dangerous back-feeds follow the instructions "Danger - Energizing Space Heaters" under item 10, Page 3.

If draw-out type potential transformers are provided, pull out the drawer holding these voltage transformers completely and disconnect all secondary connections.

After Operational Testing

Disconnect the auxiliary control-voltage source. Remove the shorting screws from the current-transformer secondary circuit and store the shorting screws for future use in the holes provided in the terminal block. Re-install the voltage transformer secondary fuses and reconnect the secondary leads, where applicable.

Manual & Shunt-Trip Switch Operation

The standard Auto-jet® switch is a 2-position switch — open (handle in the "down" position) and closed (handle in the "up" position). The standard Auto-jet® switch can be modified to be "Shunt-Trip" actuated.

Automatic shunt trip is employed to trip a switch in a circuit when there is a deviation from normal system voltage conditions such as the loss of a phase of source voltage. Metal-Enclosed Switchgear can be designed for Automatic Shunt-Trip operation following a blown fuse on a feeder circuit. Shunt-trip operation is necessary for equipment that requires balanced three-phase voltage.

Pictured in Figure 13 is the Auto-jet® switch with the trip release module. The electric schematic used to actuate the tripping module is in Figure 12.

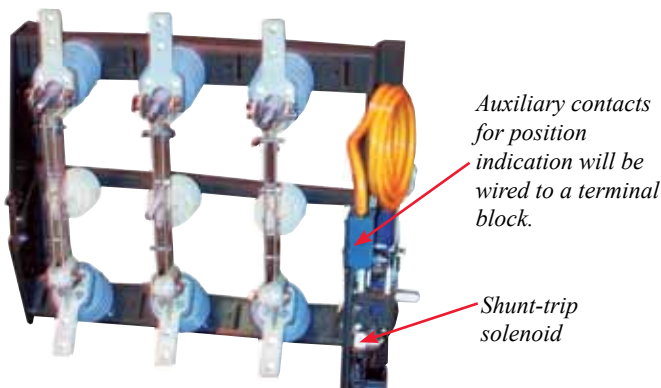

Figure 13. Switch With Shunt-Trip.

CAUTION
 When Federal Pacific Metal-Enclosed Switchgear with Shunt-Trip Switches is shipped, the switches are in the closed charged position. Please inspect to see that this switchgear arrives with the switches in the closed charged position as shown in Figure 15. If the switch blades are open, notify the factory before proceeding.

If the switch is in the charged state as shown in Figure 15, to open the switch manually, pull the "Shunt Trip Pull Knob". See Figure 14 and Figure 15.

To charge the switch, having the "Shunt Trip Module, Ready for Service", move the switch handle to the "UP" position (Figure 16) to close the switch blades. Verify that the switch blades are closed. Then pull the switch handle completely to the "DOWN" position (Figure 17). this action charges the tripping spring for the switch, which is being held closed by the solenoid latch of the shunt tripping module. Verify that the switch blades remain closed with the switch operating handle in the "DOWN" position (Figure 17). The switch mechanism is now charged and ready to be tripped by the relay circuit.

Federal Pacific Metal-Enclosed Switchgear employs field proven components for switching and protection of high voltage power distribution circuits. Briefly described in the sections that follow are these components, (switches, controllers, fuses, relays, etc.) which are available in a variety of combinations to meet system requirements.



Figure 14. Manual Shunt-Trip Knob.

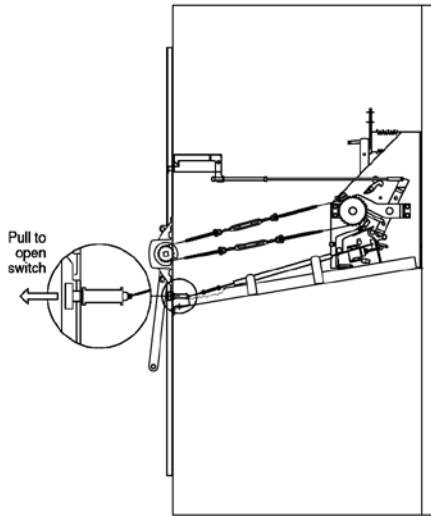

Figure 15.

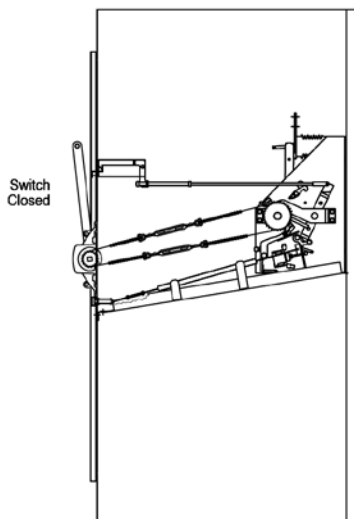

Figure 16.

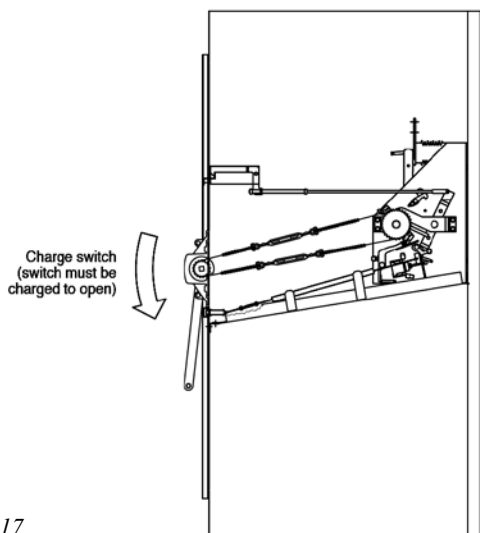

Figure 17.

For complete instructions on these components, refer to the applicable Federal Pacific instructions sheets provided in the "OPERATION AND MAINTENANCE MANUAL PACKET" that is furnished with Federal Pacific Metal-Enclosed Switchgear. The information that follows is provided for preliminary familiarization with these components.

In the event that it is desired to perform field testing to verify that the electrical circuit for shunt tripping the switch is performing properly there are two tests that can be made.

1. Checking for the correct performance of the capacitor, solenoid, and switch shunt trip mechanism.
2. Checking the Phase Loss Relay. For these tests please refer to the control circuit diagrams contained in the "OPERATION AND MAINTENANCE MANUAL PACKET".

These test can be performed with the switchgear energized but **not** loaded and with all HV doors **closed** and all interlocks and padlocks in place for normal operation. In this condition only the LV Control panel door can be opened.

1. The shunt trip switch operation/solenoid can be tested electrically by jumpering the Remote Trip terminal block points. This is a two pole terminal block which requires a set of dry contacts. Touching these two points together with a jumper will discharge the capacitor into the shunt trip coil, thereby, opening the switch. See Figure 12.
2. To test the relay itself, it is possible to remove any one of the low voltage control fuses (FU 1, FU 2, and FU 3) to simulate a loss of phase. The removal of a fuse should be performed with a pair of fuse pullers for safety. See Figure 12.

COMPONENTS AND ACCESSORIES

DANGER

To make this test with an external power source follow all the precautions to prevent backfeeds issued earlier in this document regarding the removal of fuses and shorting of CT terminals. Also, take steps not to contact any circuits connected to the output terminals of the tripping capacitor, which should be assumed to be ENERGIZED at full output voltage of the control circuit.

Fuses

Power Fuses are installed usually in feeder cubicles and may be one of two types (1) **Current Limiting** and (2) **Expulsion**. Manufacturers of Current Limiting fuses include: General Electric, Cutler-Hammer, Ferraz Shawmut, Little Fuse and Cooper Industries. Expulsion fuses are manufactured by either S&C (Type SM & SMU-20) or Cutler-Hammer (Type RBA and DBU). The mountings for the fuses are part of the Metal-Enclosed Switchgear. Instructions for installing and replacing the fuses will be found inside the box of the particular manufacturer who supplied the fuse. Expulsion fuses are NOT interchangeable

between manufacturers. In some cases Current Limiting fuses are interchangeable among manufacturers.

CAUTION

Before substituting one manufacturer's fuse or refill with a fuse made by another manufacturer, obtain confirmation of interchangeability from the fuse manufacturer whose fuse you plan to install. Federal Pacific will not approve the substitution of a fuse different from the fuse originally supplied, and will assume no liability for any substitution made for the fuse supplied with the original shipment of the switchgear.

Protective Relays

Metal-Enclosed Switchgear may contain relays for automatic shunt trip or motor operated switches. These relays are sensing various electrical circuit conditions and actuating control circuits to trip, close and/or block switch operation as designed for the application. Whenever possible Federal Pacific will use multifunctional "electronic" relays for better protection and control than usually offered by "electro-mechanical" relays.

DANGER

Usually the relays will be housed in an isolated control cabinet containing only low voltage circuits. In some cases the relays may be mounted on the cubicle door where access to the back of the relay housing can be made only when the cubicle switch is open.

Drawings showing the physical location, the schematics and connection diagrams for these relays will be found in the "OPERATION AND MAINTENANCE MANUAL PACKET" furnished with the switchgear.

For the settings and maintenance for the relays there will be instructions supplied by the relay manufacturer also located in the "OPERATION AND MAINTENANCE MANUAL PACKET".

Metering Equipment

When a single bay of Metal-Enclosed Switchgear is furnished, usually for the HV switch of a Unit Substation Transformer, Metering Equipment is rarely required. When a multi-bay (2 or more cubicles) line-up of Metal-Enclosed Switchgear is supplied, frequently at least one of the bays in the line-up will contain metering equipment. Often the metering equipment and connections of this equipment will be in accordance with specifications of the electric utility providing power to the Metal-enclosed line-up.

When Federal Pacific provides the metering equipment and instrument transformers, information on the physical location and connections of the metering equipment will be in the "OPERATION AND MAINTENANCE MANUAL PACKET".

If Federal Pacific has furnished "PROVISIONS ONLY" for the metering equipment, no supplier information is usually provided, since the metering devices are being furnished by others, usually the electric utility serving the Metal-Enclosed Switchgear.

Instrument Transformers

Metal-Enclosed Switchgear is frequently selected for distribution circuit protection because of its simplicity of not requiring instrument transformers, when only manual switch operation is only required. In many cases Metal-Enclosed Switchgear will contain shunt trip devices, motor operated switches, and metering. When these devices are included, Potential Transformers (PTs) and Current Transformers (CTs) are included with the switchgear.

Location, connection, and manufacturers' information on these devices are contained in the "OPERATION AND MAINTENANCE MANUAL PACKET".

INTERLOCKS

Interlocks are accessory devices that prevent an operation (such as opening a door or moving a switch handle), until the desired equipment states exist. (e.g. A source switch is open). Interlocks for Metal-enclosed Switchgear are usually furnished in two forms. 1) Moving mechanical interference devices (such as hardware that blocks the closing of a switch when the cubicle door is open) and; 2) Key interlocks that must be sequentially operated starting with a designated Key, before the final access or switch operation can be completed.

Key Interlocks are provided per specifications. Description of the opening and closing of doors and switches are in the "OPERATION AND MAINTENANCE MANUAL PACKET". Key interlocks are used frequently where it may be impractical to supply a mechanical interlock - for instance on cubicle hardware located several cubicles apart.

WARNING

The Key interlock scheme provided on the switchgear should be verified to the key interlock drawings in the "OPERATION AND MAINTENANCE MANUAL PACKET". To maintain the integrity of the key interlock scheme, the duplicate key(s) must be destroyed. Key interlocks are not security locks and are not intended to be used in the place of padlocks. Entrance bays may include key interlocks that guard against opening the enclosure door, unless an associated upstream or downstream device is open. If such key interlocks are furnished, do not attempt to open the enclosure door unless the associated device is open. See Figure 18.

CAUTION

Use of excessive force in an attempt to operate switches contrary to the correct sequence dictated by the key interlock scheme may damage handles or latching mechanisms.

MAINTENANCE

Only qualified persons should be permitted to operate or maintain high-voltage switchgear.

Maintenance recommendations include:

- (A) Periodic cleaning of: (1) insulators of the interrupter switch, fuse, and bus-supports; (2) barriers; (3) cable-terminating devices; and (4) vent filters (if furnished).
- (B) Yearly inspection of switch and fuse contacts for proper cleanliness and alignment based on environmental conditions.
- (C) Periodic exercising (yearly) of all switches and operators.
- (D) Periodic lubrication of switch operators and drives with a recommended lubricant such as NYE Rheolube 363.
- (E) Checking of the integrity of the enclosure finish and repairing of scratches or chips with the appropriate touch-up finish.
- (F) Periodically verifying the proper functioning of interlocks as described under "Interlocks".

CAUTION

When control-source fuse replacement is required in Automatic Source Transfer Controls, be sure to use only fuses as designated in the applicable switch operator instruction sheets. When bulb replacement is performed in source-transfer controls, use only designated replacement bulbs. Costly damage to the switch operator or controls could result when the wrong fuse or bulb is used.

DANGER

When access to high-voltage bays is required for these purposes, it must be restricted to qualified persons only, who must observe the following procedures:

1. Adhere to prescribed safety rules at all times.
2. To prevent dangerous voltage back feeds disconnect the fuses, interrupter switches, power switching equipment, their mechanisms, and any other devices from all power sources and all control sources before that device is inspected, serviced, or repaired.
3. Always assume both sets of power terminals on any interrupter switch, fuse, or terminal to be energized.

All voltage transformers must be disconnected when external voltage is used to test any secondary side wiring or devices. This precaution will avoid energizing the high voltage conductors back-fed through the voltage transformers or sensors. If draw-out type transformers are furnished, withdraw the voltage transformers completely and disconnect the secondary connections. Remove the primary fuses of the voltage transformers and disconnect the secondaries by removing the secondary fuses or by disconnecting the secondary leads.

4. If maintenance is to be performed on ammeters, short-circuit the secondary connections of the associated current transformer with the shorting type terminal block prior to removal of the ammeter.
5. Test for voltage. Qualified persons should be certain that they have the knowledge to operate the correct test equipment for determining the voltage on both sets of power terminals for any fuse or interrupter-switch equipment.
6. After the switchgear has been completely disconnected from all sources of power and tested, properly connect grounding leads to both sides of the equipment, that include the incoming and the outgoing phases of the equipment to be maintained.
7. Padlock and tag equipment in accordance with the user's standard operating procedures.
8. Follow instructions supplied by the manufacturer of the equipment to be maintained or other pertinent information.
9. Make certain the switch-operating handles, operator housings, and metal enclosures are properly grounded. No equipment should be serviced unless such grounds are properly made and verification is made that all the equipment live parts are at ground potential.
10. NOTE: In the servicing or repair of space heaters, voltage-transformer secondary wiring, and any other components located in the high-voltage compartment, all of the preceding safety procedures apply.

DANGER

Returning the Equipment to Service

Observe the following procedures:

1. Reconnect any low-voltage terminals that may have been disconnected when servicing the gear.
2. Make sure that no barrier is touching a live HV component, insulator or bus.
3. Open any grounding switch, or remove other temporary grounding means, before closing the associated interrupter switches.
4. Close and securely latch each switchgear bay door before energizing the circuit or operating any switching device.
5. Lock interrupter switches in the **open** or **closed** position as dictated by the electric power system design.
6. Padlock all doors, switch-operating handles, and covers before leaving the installation site, even momentarily. Observe this procedure even in those cases where the gear is accessible only to qualified persons.

WARRANTY

The standard warranty for Metal-Enclosed Switchgear is contained in the Federal Pacific Standard Conditions of Sale form "F012N01".

With respect to major components, Federal Pacific's Standard Conditions of Sale provide the following:

The Federal Pacific warranty does not apply to major components not of Federal Pacific manufacture such as: surge arresters, current-limiting fuses, instrument transformers, relays and meters, circuit breakers, and terminators. However, Federal Pacific, the seller, will assign to purchaser all manufacturer's warranties that apply to such major components.



Figure 18. Key interlocks on manual switch-operating handle to guard against possible undesirable paralleling and to prevent opening the door unless downstream switches are open.



Every effort is made to ensure that customers receive an up-to-date instruction manual on the use of Federal Pacific products; however, from time to time, modifications to our products may without notice make the information contained herein subject to alteration.