



Buck and Boost Dry-Type Transformers

Indoor / Outdoor

Instructions for the Selection, Safe Handling, Installation and Operation of Buck and Boost Dry-Type Transformers

For more detailed selection and ratings go to the Federal Pacific link:
www.federalpacific.com/bbcalc.xls

How to Select the Proper Transformer

To select the proper transformer for Buck-Boost applications, determine:

- 1. Input line voltage** - The voltage that you want to buck (decrease) or boost (increase). This can be found by measuring the supply line voltage with a voltmeter.
- 2. Load voltage** - The voltage at which your equipment is designed to operate. This is listed on the nameplate of the load equipment.
- 3. Load KVA or Load Amps** - You do not need to know both - one or the other is sufficient for selection purposes. This information usually can be found on the nameplate of the equipment that you want to operate.
- 4. Number of phases** - Single or three phase line and load should match because a transformer is not capable of converting single to three phase. It is, however, a common application to make a single phase transformer connection from a three phase supply by use of one leg of the three phase supply circuit. Care must always be taken not to overload the leg of the three-phase supply. This is particularly true in a Buck-Boost application because the supply must provide for the load KVA, not just the nameplate rating of the Buck-Boost transformer.
- 5. Frequency** - The supply line frequency must be the same as the frequency of the equipment to be operated - either 50 or 60 cycles.

How to Use Selection Charts

- 1. Choose the selection table** with the correct number of phases. Tables I, III and V for single phase and Tables II, IV and VI for three phase transformers. Tables I and II are for 120 x 240 - 12/24 volts, tables III and IV are for 120 x 240 - 16/32 volts and tables V and VI are for 240 x 480 - 24/48 volts.
- 2. Line/Load voltage combinations** are listed across the top of the selection table. Select a line/load voltage combination which comes closest to matching your application.
- 3. Follow the selected column** down until you find either the load KVA or load amps of your application. If you do not find the exact value, go on to the next highest rating.
- 4. Now follow across the table** to the far left-hand side to find the KVA of the transformer you need.
- 5. Follow the column of your line/load voltage** to the bottom to find the connection diagram for this application. NOTE: Connection diagrams show low voltage and high voltage connection terminals. Either can be input or output depending on buck or boost application.
- 6. In the case of three phase loads** either two or three single phase transformers are required as indicated in the "quantity required" line at the bottom of Table II, IV or VI. The selection is dependent on whether a Wye connected bank of three transformers with a neutral is required or whether an open Delta connected bank of two transformers for a Delta connected load will be suitable. Wye connected banks should be used with 3-phase, 4 wire supplies only.

For line/load voltages not listed on table, use the pair listed on the table that is slightly above your application for reference. Then apply the first formula at the bottom of Table II, IV or VI to determine "New" output voltage. The new KVA rating can be found using the second formula.

Operating and Installation Instructions for Encapsulated Dry-Type Transformers

General

The encapsulated dry-type transformer is a totally enclosed, non-ventilated, compound filled, insulating transformer which has been completely assembled at the factory and is ready for operation. These transformers are completely encased in a sturdy steel housing. A large wiring compartment with conduit knockouts permits fast wiring connections. This wiring compartment is accessible by a removable cover.

Inspection

The transformer should be unpacked as soon as it is received and examined for possible damage during shipment. Should damage be found, a claim should be filed immediately with the transportation company.

Handling

Care should be exercised in handling dry-type transformers. Lifting eyes or similar lifting means are provided on most sizes.

Installation

These encapsulated dry-type transformers are UL listed for indoor/outdoor applications. They may be installed on walls, beams, platforms, or other locations. They are ideal for applications in dusty industrial areas. Dry-type transformers must be protected by lightning arresters or other suitable equipment from outside lines which may cause lightning and switching surges to be transmitted to the transformer. The enclosure should be grounded to a water pipe or similar type of effective common ground. Transformers should not be loaded beyond their nameplate rating since overloads will result in a reduced life expectancy.

Connections

Refer to the nameplate for voltage combinations, frequency, number of phases, and tap connections. All leads not being used must be properly insulated.

Maintenance

Practically no maintenance is required on a dry-type transformer. Encapsulated types only require wiping off dust or dirt from the outside of the case.

Typical Three-Phase Buck-Boost Autotransformer Installation

Use quantity of Buck-Boost Transformer(s) indicated on chart for connection to be made. Quantity required may vary from quantity shown in this illustration.

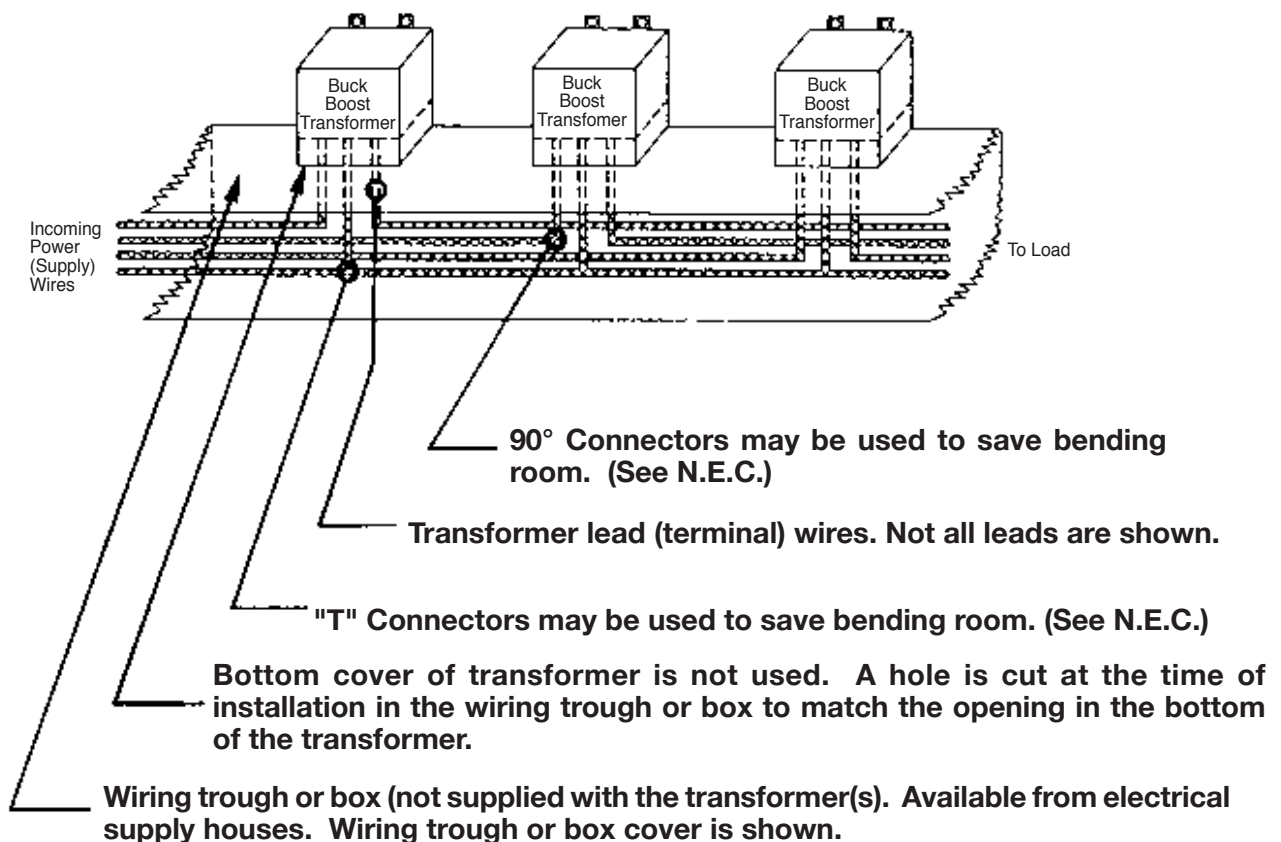

Buck-Boost Connection Diagram

Use the following information for single-phase autotransformer connections.

NOTE: Inputs and outputs may be reversed; KVA capacity remains constant. All applications are suitable for 60 Hz. only.

IMPORTANT: Refer to the N.E.C. (National Electrical Code) Article 450-4 for overcurrent protection of an autotransformer.

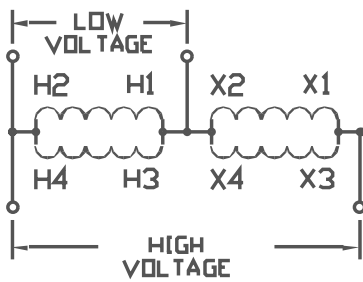

FIGURE A

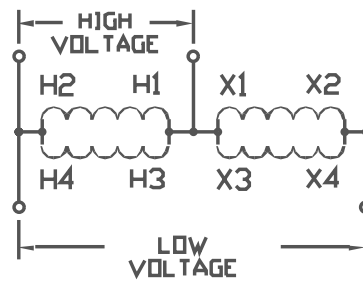

FIGURE A1

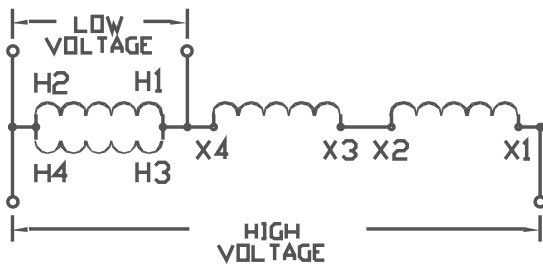

FIGURE B



FIGURE B1

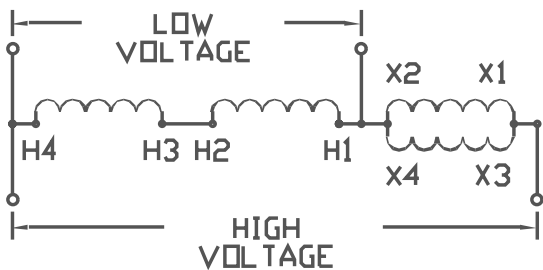

FIGURE C

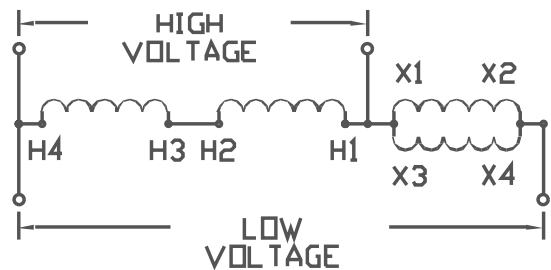

FIGURE C1

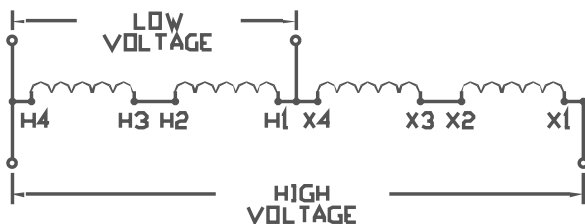

FIGURE D

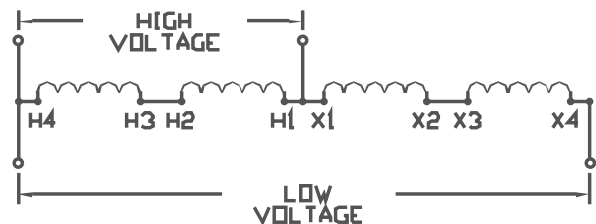

FIGURE D1

Buck-Boost Connection Diagram

Use the following information for single-phase autotransformer connections.

NOTE: Inputs and outputs may be reversed; KVA capacity remains constant. All applications are suitable for 60 Hz. only.

IMPORTANT: Refer to the N.E.C. (National Electrical Code) Article 450-4 for overcurrent protection of an autotransformer.

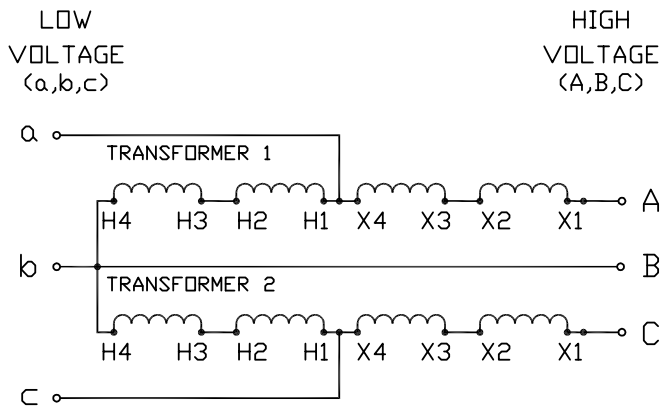

FIGURE G

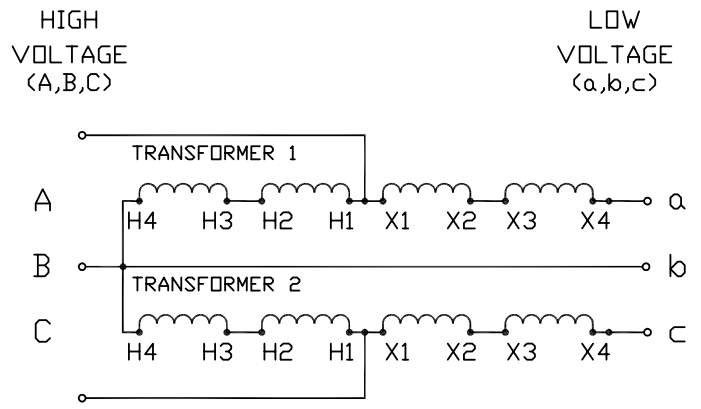

FIGURE L

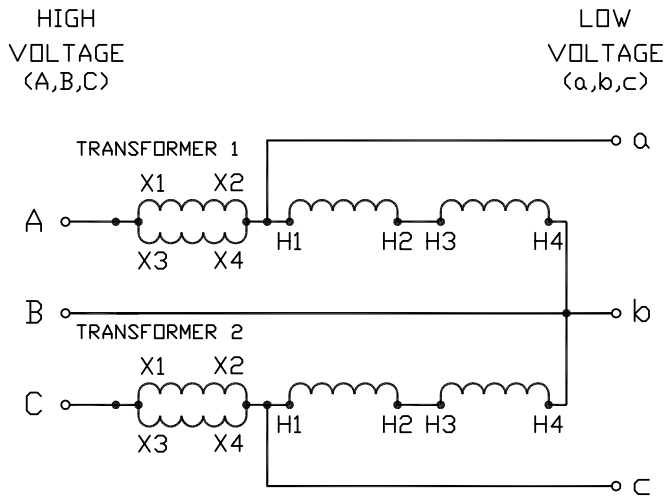

FIGURE H

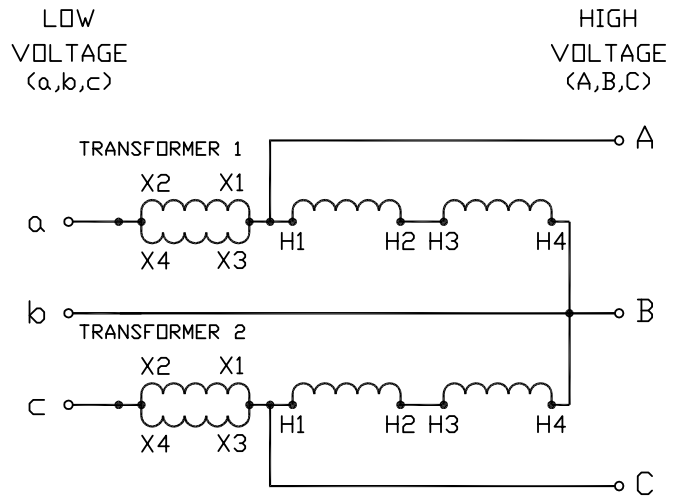

FIGURE H1

Buck-Boost Connection Diagram

Use the following information for single-phase autotransformer connections.

NOTE: Inputs and outputs may be reversed; KVA capacity remains constant. All applications are suitable for 60 Hz. only.

IMPORTANT: Refer to the N.E.C. (National Electrical Code) Article 450-4 for overcurrent protection of an autotransformer.

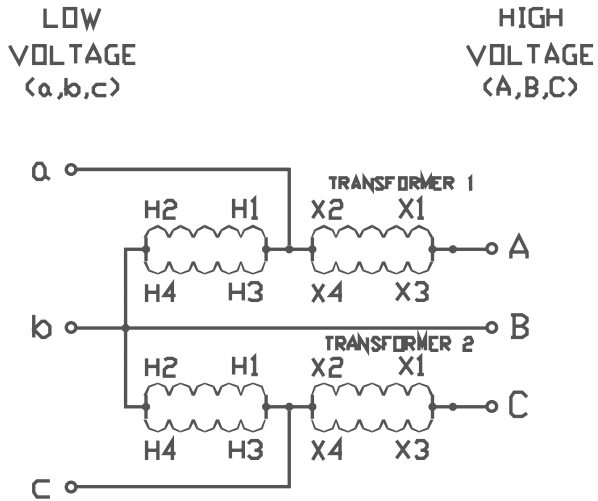

FIGURE M

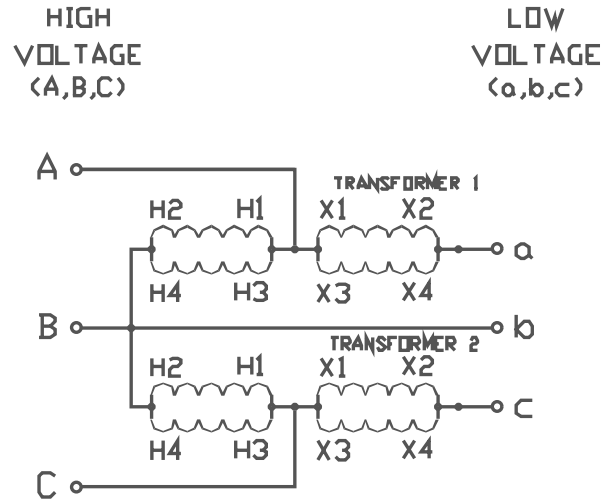

FIGURE M1

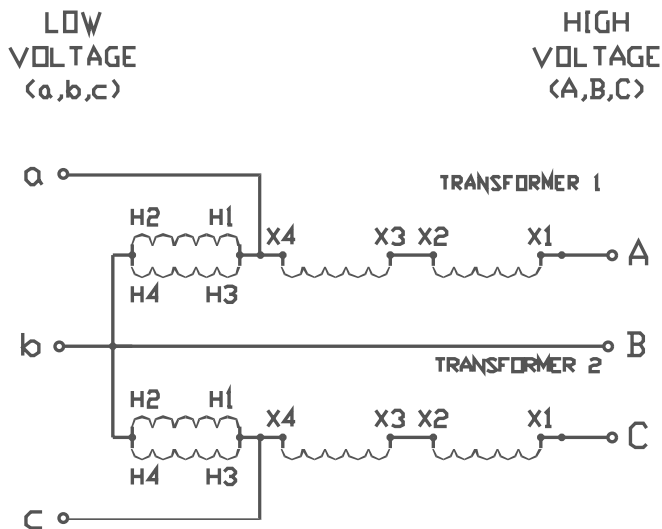

FIGURE N

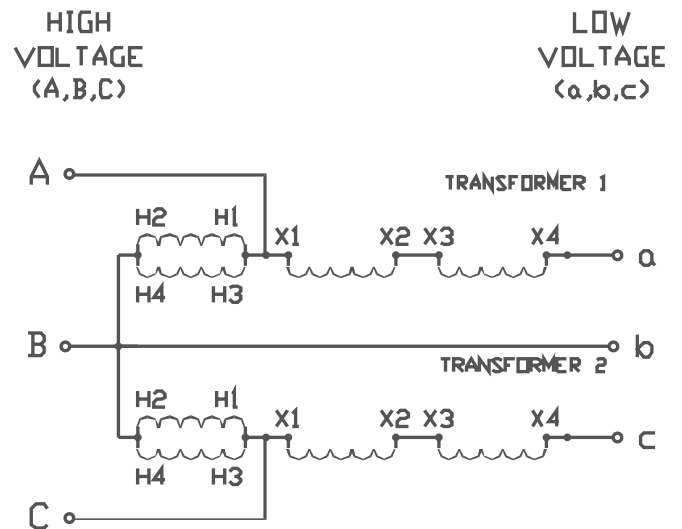

FIGURE N1

Buck-Boost Connection Diagram

Use the following information for single-phase autotransformer connections.

NOTE: Inputs and outputs may be reversed; KVA capacity remains constant. All applications are suitable for 60 Hz. only.

IMPORTANT: Refer to the N.E.C. (National Electrical Code) Article 450-4 for overcurrent protection of an autotransformer.

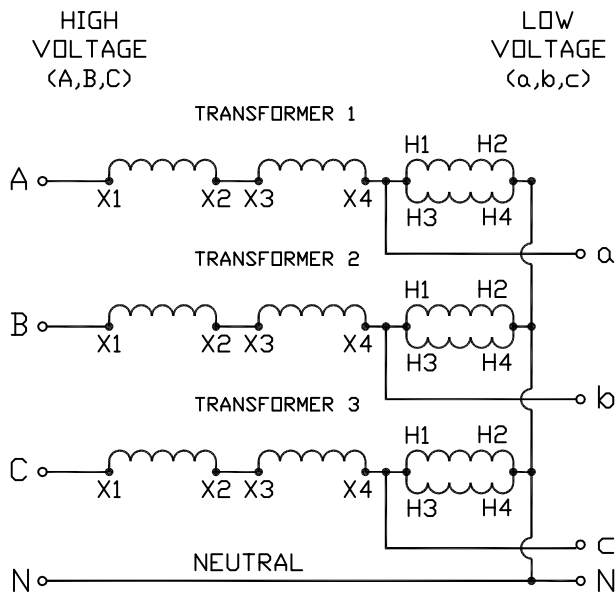

FIGURE E

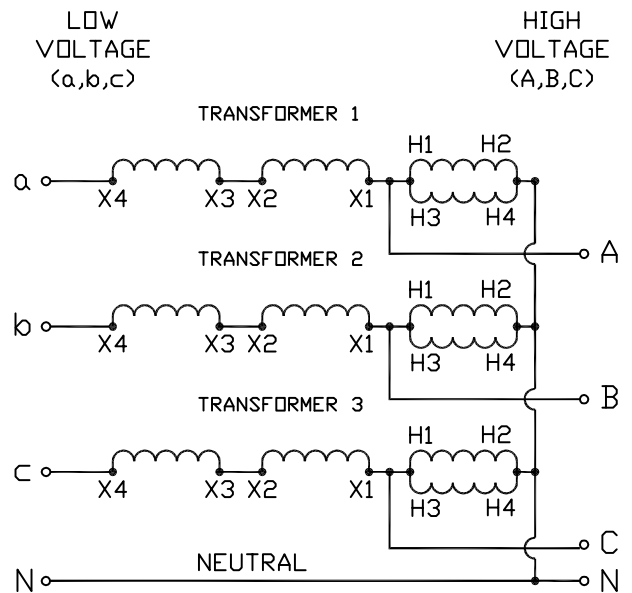

FIGURE E1

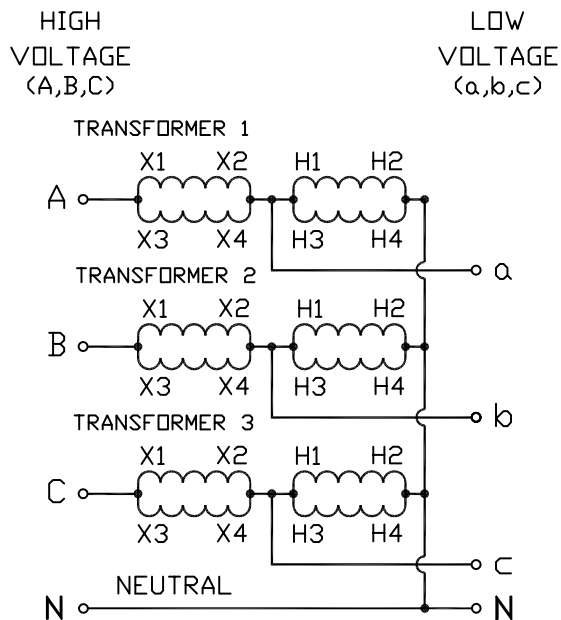

FIGURE F

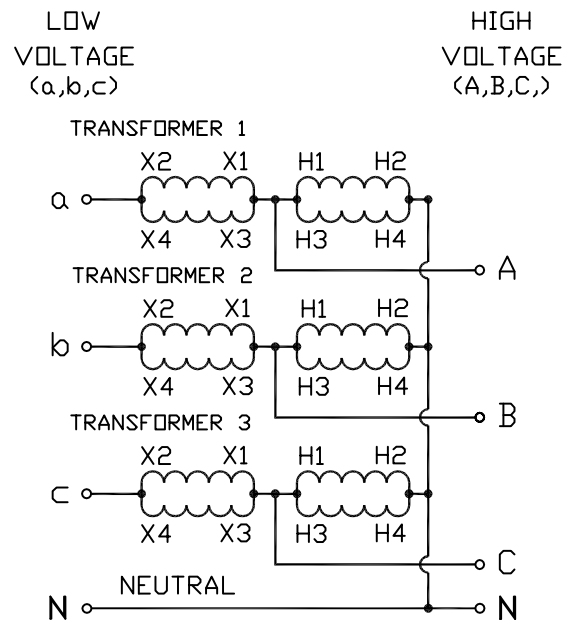

FIGURE F1

Buck-Boost Connection Diagram

Use the following information for single-phase autotransformer connections.

NOTE: Inputs and outputs may be reversed; KVA capacity remains constant. All applications are suitable for 60 Hz. only.

IMPORTANT: Refer to the N.E.C. (National Electrical Code) Article 450-4 for overcurrent protection of an autotransformer.

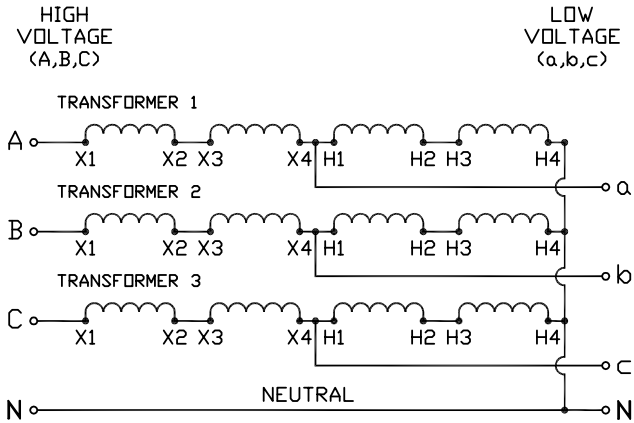

FIGURE J

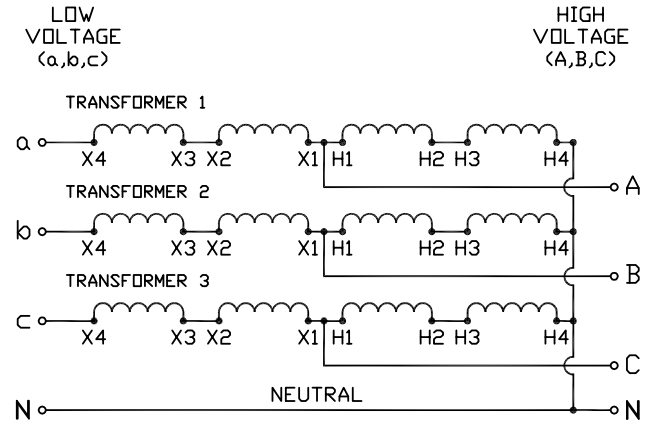

FIGURE J1

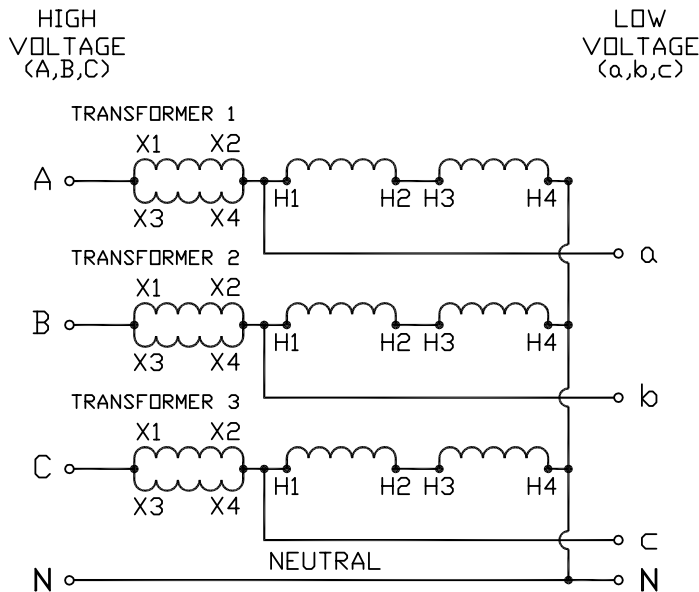

FIGURE K

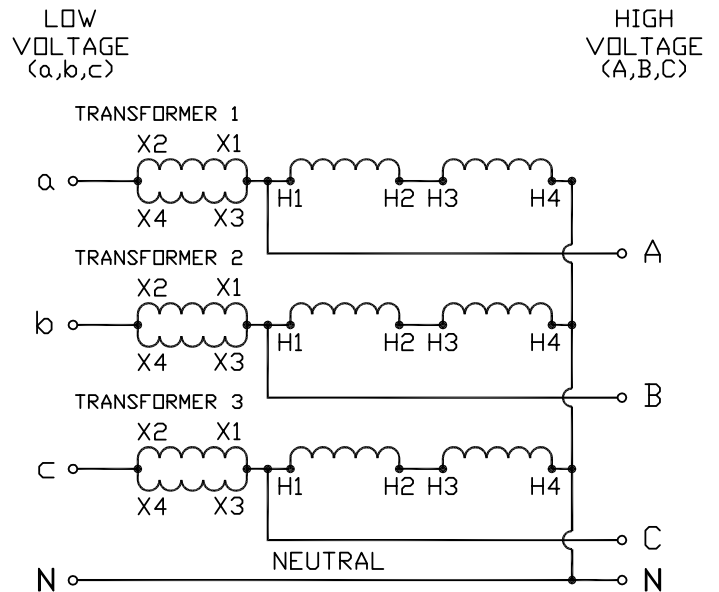

FIGURE K1

120 x 240 Volts Primary - 12/24 Volts Secondary • Buck - Boost Dry-Type Transformers

AMPS = Load Amps
KVA = Load Circuit KVA

Single-Phase

TABLE I		BOOSTING								BUCKING					
Catalog Number	Line Voltage	96	100	105	109	189	208	218	220	125	132	229	245	250	252
	Load Voltage	115	120	116	120	208	229	240	242	114	120	208	223	227	240
SB12N.050F	KVA	0.24	0.25	0.48	0.50	0.43	0.48	0.50	0.50	0.52	0.55	0.48	0.51	0.52	1.05
	AMPS	2.08	2.08	4.17	4.17	2.08	2.08	2.08	2.08	4.58	4.58	2.29	2.29	2.29	4.38
SB12N.100F	KVA	0.48	0.50	0.96	1.00	0.87	0.95	1.00	1.01	1.04	1.10	0.95	1.02	1.04	2.10
	AMPS	4.17	4.17	8.33	8.33	4.17	4.17	4.17	4.17	9.17	9.17	4.58	4.58	4.58	8.75
SB12N.150F	KVA	0.72	0.75	1.44	1.50	1.30	1.43	1.50	1.51	1.56	1.65	1.43	1.53	1.56	3.15
	AMPS	6.25	6.25	12.50	12.50	6.25	6.25	6.25	6.25	13.75	13.75	6.87	6.87	6.87	13.13
SB12N.250F	KVA	1.20	1.25	2.41	2.50	2.17	2.38	2.50	2.52	2.60	2.75	2.39	2.55	2.60	5.25
	AMPS	10.42	10.42	20.83	20.83	10.42	10.42	10.42	10.42	22.92	22.92	11.46	11.46	11.46	21.88
SB12N.500F	KVA	2.40	2.50	4.81	5.00	4.33	4.77	5.00	5.04	5.21	5.50	4.77	5.10	5.21	10.50
	AMPS	20.83	20.83	41.67	41.67	20.83	20.83	20.83	20.83	45.83	45.83	22.92	22.92	22.92	43.75
SB12N.750F	KVA	3.60	3.75	7.22	7.49	6.5	7.15	7.49	7.56	7.81	8.25	7.16	7.66	7.81	15.75
	AMPS	31.25	31.25	62.50	62.50	31.25	31.25	31.25	31.25	68.75	68.75	34.37	34.37	34.37	65.63
SB12N1F	KVA	4.80	5.00	9.63	9.99	8.66	9.53	9.99	10.08	10.42	11.00	9.54	10.21	10.42	21.00
	AMPS	41.67	41.67	83.33	83.33	41.67	41.67	41.67	41.67	91.67	91.67	45.83	45.83	45.83	87.50
SB12N1.5F	KVA	7.20	7.5	14.44	14.99	12.99	14.30	14.99	15.13	15.62	16.50	14.31	15.31	15.62	31.50
	AMPS	62.50	62.50	125.00	125.00	62.50	62.50	62.50	62.50	137.50	137.50	68.75	68.75	68.75	131.25
SB12N2F	KVA	9.60	10.00	19.25	19.98	17.32	19.07	19.98	20.17	20.83	22.00	19.08	20.42	20.83	42.00
	AMPS	83.33	83.33	166.67	166.67	83.33	83.33	83.33	83.33	183.33	183.33	91.67	91.67	91.67	175.00
SB12N3F	KVA	14.40	15.00	28.88	29.98	25.99	28.60	29.98	30.25	31.25	33.00	28.62	30.62	31.25	63.00
	AMPS	125.00	125.00	250.00	250.00	125.00	125.00	125.00	125.00	275.00	275.00	137.50	137.50	137.50	262.50
SB12N5F	KVA	24.00	25.00	48.13	49.96	43.31	47.67	49.96	50.42	52.08	55.00	47.71	51.04	52.08	105.00
	AMPS	208.33	208.33	416.67	416.67	208.33	208.33	208.33	208.33	458.33	458.33	229.17	229.17	229.17	437.50
*DIAGRAM		B	B	A	A	D	D	D	D	A	A	D	D	D	C

Three-Phase

TABLE II		BOOSTING								BUCKING					
Catalog Number	Line Voltage	189Y/109	195Y/113	200Y/115	208Y/120	416Y/240	416Y/240	189	208	220	218	229	250	255	264
	Load Voltage	208Y/120	234Y/135	240Y/139	229Y/132	458Y/264	437Y/252	208	229	242	208	208	227	232	240
SB12N.050F	KVA	1.50	0.84	0.87	1.65	1.65	3.15	0.75	0.83	0.87	1.57	0.83	0.90	0.92	0.95
	AMPS	4.17	2.08	2.08	4.17	2.08	4.17	2.08	2.08	2.08	4.38	2.29	2.29	2.29	2.29
SB12N.100F	KVA	3.00	1.69	1.73	3.30	3.30	6.30	1.50	1.65	1.75	3.15	1.65	1.80	1.84	1.91
	AMPS	8.33	4.17	4.17	8.33	4.17	8.33	4.17	4.17	4.17	8.75	4.58	4.58	4.58	4.58
SB12N.150F	KVA	4.5	2.53	2.60	4.95	4.95	9.46	2.25	2.48	2.62	4.72	2.48	2.71	2.76	2.86
	AMPS	12.50	6.25	6.25	12.50	6.25	12.50	6.25	6.25	6.25	13.13	6.87	6.87	6.88	6.88
SB12N.250F	KVA	7.50	4.22	4.33	8.26	8.26	15.76	3.75	4.13	4.37	7.87	4.13	4.51	4.60	4.76
	AMPS	20.83	10.42	10.42	20.83	10.42	20.83	10.42	10.42	10.42	21.88	11.46	11.46	11.46	11.46
SB12N.500F	KVA	15.00	8.44	8.66	16.51	16.51	31.52	7.50	8.26	8.73	15.73	8.26	9.02	9.20	9.53
	AMPS	41.67	20.83	20.83	41.67	20.83	41.67	20.83	20.83	20.83	43.75	22.92	22.92	22.92	22.92
SB12N.750F	KVA	22.51	12.67	12.99	24.77	24.77	47.28	11.25	12.38	13.10	23.60	12.39	13.53	13.80	14.29
	AMPS	62.50	31.25	31.25	62.50	31.25	62.50	31.25	31.25	31.25	65.63	34.37	34.37	34.37	34.38
SB12N1F	KVA	30.01	16.89	17.32	33.02	33.02	63.05	15.00	16.51	17.46	31.47	16.53	18.04	18.40	19.05
	AMPS	83.33	41.67	41.67	83.33	41.67	83.33	41.67	41.67	41.67	87.50	45.83	45.83	45.83	45.83
SB12N1.5F	KVA	45.01	25.66	25.98	49.54	49.54	94.57	22.51	24.77	26.20	47.20	24.79	27.06	27.60	28.58
	AMPS	125.00	62.50	62.50	125.00	62.50	125.00	62.50	62.50	62.50	131.25	68.75	68.75	68.75	68.75
SB12N2F	KVA	60.02	33.77	34.64	66.05	66.05	126.09	30.01	33.02	34.93	62.93	33.05	36.08	36.81	38.11
	AMPS	166.67	83.33	83.33	166.67	83.33	166.67	83.33	83.33	83.33	175.00	91.67	91.67	91.67	91.67
SB12N3F	KVA	90.02	50.66	51.96	99.07	99.07	189.14	45.01	49.54	52.39	94.40	49.58	54.13	55.21	57.16
	AMPS	250.00	125.00	125.00	250.00	125.00	250.00	125.00	125.00	125.00	262.50	137.50	137.50	137.50	137.50
SB12N5F	KVA	150.04	84.44	86.60	165.12	165.12	315.23	75.02	82.56	87.32	157.33	82.63	90.21	92.02	95.26
	AMPS	416.67	208.33	208.33	416.67	208.33	416.67	208.33	208.33	208.33	437.50	229.17	229.17	229.17	229.17
No. of Transformers		3	3	3	3	3	3	2	2	2	2	2	2	2	2
*DIAGRAM		F	E	E	F	J	K	G	G	G	H	G	G	G	G

Output voltage for lower input voltage can be found by: $\frac{\text{Rated Output Voltage}}{\text{Rated Input Voltage}} \times \text{Input Actual Voltage} = \text{Output New Voltage}$.

Output KVA available at reduced input voltage can be found by: $\frac{\text{Actual Input Voltage}}{\text{Rated Input Voltage}} \times \text{Output KVA} = \text{New KVA Rating}$.

120 x 240 Volts Primary - 16/32 Volts Secondary • Buck - Boost Dry-Type Transformers

AMPS = Load Amps
KVA = LoadCircuit KVA

Single-Phase

TABLE III		BOOSTING								BUCKING					
Catalog Number	Line Voltage	95	100	105	208	215	215	220	225	135	240	240	245	250	255
	Load Voltage	120	113	119	236	244	229	235	240	120	212	225	230	234	239
SB16N.050F	KVA	0.19	0.35	0.37	0.37	0.38	0.72	0.73	0.75	0.42	0.38	0.75	0.77	0.78	0.80
	AMPS	1.56	3.13	3.13	1.56	1.56	3.12	3.13	3.12	3.54	1.77	3.33	3.33	3.33	3.33
SB16N.100F	KVA	0.38	0.71	0.74	0.74	0.76	1.43	1.47	1.50	0.84	0.75	1.50	1.53	1.56	1.59
	AMPS	3.13	6.25	6.25	3.13	3.13	6.25	6.25	6.25	7.08	3.54	6.67	6.67	6.67	6.67
SB16N.150F	KVA	0.56	1.06	1.12	1.11	1.14	2.15	2.20	2.25	1.27	1.13	2.25	2.30	2.34	2.39
	AMPS	4.69	9.38	9.38	4.69	4.69	9.37	9.37	9.37	10.63	5.31	10.00	10.00	10.00	10.00
SB16N.250F	KVA	0.94	1.77	1.86	1.84	1.90	3.58	3.67	3.75	2.11	1.88	3.75	3.83	3.91	3.98
	AMPS	7.81	15.63	15.63	7.81	7.81	15.62	15.62	15.62	17.71	8.85	16.67	16.67	16.67	16.67
SB16N.500F	KVA	1.88	3.54	3.72	3.68	3.81	7.17	7.33	7.50	4.22	3.75	7.50	7.66	7.81	7.97
	AMPS	15.63	31.25	31.25	15.63	15.63	31.25	31.25	31.25	35.42	17.71	33.33	33.33	33.33	33.33
SB16N.750F	KVA	2.82	5.31	5.58	5.53	5.71	10.75	11.00	11.25	6.33	5.63	11.25	11.48	11.72	11.95
	AMPS	23.44	46.88	46.88	23.44	23.44	46.87	46.87	46.87	53.13	26.56	50.00	50.00	50.00	50.00
SB16N1F	KVA	3.76	7.08	7.44	7.37	7.61	14.33	14.67	15.00	8.44	7.50	15.00	15.31	15.62	15.94
	AMPS	31.25	62.50	62.50	31.25	31.25	62.50	62.50	62.50	70.83	35.42	66.67	66.67	66.67	66.67
SB16N1.5F	KVA	5.64	10.63	11.16	11.05	11.42	21.50	22.00	22.50	12.66	11.25	22.50	22.97	23.44	23.91
	AMPS	46.88	93.75	93.75	46.88	46.88	93.75	93.75	93.75	106.25	53.13	100.00	100.00	100.00	100.00
SB16N2F	KVA	7.52	14.71	14.88	14.73	15.23	28.67	29.33	30.00	16.88	15.00	30.00	30.62	31.25	31.87
	AMPS	62.50	125.00	125.00	62.50	62.50	125.00	125.00	125.00	141.67	70.83	133.33	133.33	133.33	133.33
SB16N3F	KVA	11.28	21.25	22.31	22.10	22.84	43.00	44.00	45.00	25.31	22.50	45.00	45.94	46.87	47.81
	AMPS	93.75	187.50	187.50	93.75	93.75	187.50	187.50	187.50	212.50	106.25	200.00	200.00	200.00	200.00
SB16N5F	KVA	18.80	35.42	37.19	36.83	38.07	71.67	73.33	75.00	42.19	37.50	75.00	76.56	78.12	79.69
	AMPS	156.25	312.50	312.50	156.25	156.25	312.50	312.50	312.50	354.17	177.08	333.33	333.33	333.33	333.33
*DIAGRAM		B	A	A	D	D	C	C	C	A	D	C	C	C	C

Three-Phase

TABLE IV		BOOSTING					BUCKING					
Catalog Number	Line Voltage	183Y/106	208Y/120	195	208	225	240	245	250	256	265	272
	Load Voltage	208Y/120	236Y/136	208	236	240	208	230	234	240	234	240
SB16N.050F	KVA	1.12	1.28	1.13	0.64	1.30	0.56	1.33	1.35	1.39	0.72	0.74
	AMPS	3.13	3.13	3.12	1.56	3.12	1.56	3.33	3.33	3.33	1.77	1.77
SB16N.100F	KVA	2.25	2.55	2.25	1.28	2.60	1.13	2.65	2.71	2.77	1.43	1.47
	AMPS	6.25	6.25	6.25	3.13	6.25	3.13	6.67	6.67	6.67	3.54	3.54
SB16N.150F	KVA	3.37	3.83	3.38	1.91	3.90	1.69	3.98	4.06	4.16	2.15	2.21
	AMPS	9.38	9.38	9.37	4.69	9.37	4.69	10.00	10.00	10.00	5.31	5.31
SB16N.250F	KVA	5.61	6.38	5.63	3.19	6.50	2.81	6.63	6.77	6.93	3.59	3.68
	AMPS	15.63	15.62	15.62	7.81	15.62	7.81	16.67	16.67	16.67	8.85	8.85
SB16N.500F	KVA	11.23	12.76	11.26	6.38	12.99	5.63	13.26	13.53	13.86	7.17	7.36
	AMPS	31.25	31.25	31.25	15.63	31.25	15.63	33.33	33.33	33.33	17.71	17.71
SB16N.750F	KVA	16.84	19.14	16.89	9.58	19.49	8.44	19.89	20.30	20.78	10.76	11.04
	1AMPS	46.88	46.88	46.87	23.44	46.87	23.44	50.00	50.00	50.00	26.56	26.56
SB16N1F	KVA	22.45	25.52	22.52	12.76	25.98	11.26	26.52	27.06	27.71	14.34	14.72
	AMPS	62.50	62.50	62.50	31.25	62.50	31.25	66.67	66.67	66.67	35.42	35.42
SB16N1.5F	KVA	33.68	38.28	33.77	19.14	38.97	16.89	39.78	40.59	41.57	21.52	22.08
	AMPS	93.75	93.75	93.75	46.88	93.75	46.88	100.00	100.00	100.00	53.13	53.13
SB16N2F	KVA	44.90	51.04	45.03	25.52	51.96	22.52	53.04	54.13	55.43	28.69	29.44
	AMPS	125.00	125.00	125.00	62.50	125.00	62.50	133.33	133.33	133.33	70.83	70.83
SB16N3F	KVA	67.36	76.56	67.55	38.28	77.94	33.77	79.57	81.19	83.14	43.03	44.17
	AMPS	187.50	187.50	187.50	93.75	187.50	93.75	200.00	200.00	200.00	106.25	106.25
SB16N5F	KVA	112.26	127.59	112.58	63.80	129.90	56.29	132.61	135.32	138.56	71.72	73.61
	AMPS	312.50	312.50	312.50	156.25	312.50	156.25	333.33	333.33	333.33	177.08	177.08
No. of Transformers		3	3	2	2	2	2	2	2	2	2	2
*DIAGRAM		F	F	H	G	H	L	H	H	H	G	G

Output voltage for lower input voltage can be found by: $\frac{\text{Rated Output Voltage}}{\text{Rated Input Voltage}} \times \text{Input Actual Voltage} = \text{Output New Voltage.}$

Output KVA available at reduced input voltage can be found by: $\frac{\text{Actual Input Voltage}}{\text{Rated Input Voltage}} \times \text{Output KVA} = \text{New KVA Rating.}$

240 x 480 Volts Primary - 24/48 Volts Secondary • Buck - Boost Dry-Type Transformers

AMPS = Load Amps
KVA = Load Circuit KVA

Single-Phase

Catalog Number	Line Voltage	BOOSTING									BUCKING				
		230	380	416	425	430	435	440	450	460	132	277	480	480	504
	Load Voltage	276	418	458	468	473	457	462	495	483	126	231	436	457	480
SB24N.050F	KVA	0.29	0.44	0.48	0.49	0.49	0.95	0.96	0.52	1.01	0.28	0.29	0.50	1.00	1.05
	AMPS	1.04	1.04	1.04	1.04	1.04	2.08	2.08	1.04	2.08	2.19	1.25	1.15	2.19	2.19
SB24N.100F	KVA	0.58	0.87	0.95	0.97	0.99	1.90	1.93	1.03	2.01	0.55	0.58	1.00	2.00	2.10
	AMPS	2.08	2.08	2.08	2.08	2.08	4.17	4.17	2.08	4.17	4.38	2.50	2.29	4.38	4.38
SB24N.150F	KVA	0.86	1.31	1.43	1.46	1.48	2.85	2.89	1.55	3.02	0.83	0.87	1.50	3.00	3.15
	AMPS	3.13	3.13	3.13	3.13	3.13	6.25	6.25	3.13	6.25	6.56	3.75	3.44	6.56	6.56
SB24N.250F	KVA	1.44	2.18	2.38	2.43	2.46	4.76	4.81	2.58	5.03	1.38	1.44	2.50	5.00	5.25
	AMPS	5.21	5.21	5.21	5.21	5.21	10.42	10.42	5.21	10.42	10.94	6.25	5.73	10.94	10.94
SB24N.500F	KVA	2.88	4.35	4.77	4.87	4.93	9.52	9.63	5.16	10.06	2.75	2.89	5.00	10.00	10.50
	AMPS	10.42	10.42	10.42	10.42	10.42	20.83	20.83	10.42	20.83	21.88	12.50	11.46	21.88	21.88
SB24N.750F	KVA	4.31	6.53	7.15	7.30	7.39	14.27	14.44	7.73	15.09	4.13	4.33	7.50	15.00	15.75
	AMPS	15.63	15.63	15.62	15.63	15.63	31.25	31.25	15.63	31.25	32.81	18.75	17.19	32.81	32.81
SB24N1F	KVA	5.75	8.71	9.53	9.74	9.85	19.03	19.25	10.31	20.13	5.50	5.77	10.00	20.00	21.00
	AMPS	20.83	20.83	20.83	20.83	20.83	41.67	41.67	20.83	41.67	43.75	25.00	22.92	43.75	43.75
SB24N1.5F	KVA	8.63	13.06	14.30	14.61	14.78	28.55	28.88	15.47	30.19	8.25	8.66	15.00	30.00	31.50
	AMPS	31.25	31.25	31.25	31.25	31.25	62.50	62.50	31.25	62.50	65.63	37.50	34.37	65.63	65.63
SB24N2F	KVA	11.50	17.42	19.07	19.48	19.71	38.06	38.50	20.63	40.25	11.00	11.54	20.00	40.00	42.00
	AMPS	41.67	41.67	41.67	41.67	41.67	83.33	83.33	41.67	83.33	87.50	50.00	45.83	87.50	87.50
SB24N3F	KVA	17.25	26.13	28.60	29.22	29.56	57.09	57.75	30.94	60.38	16.50	17.31	30.00	60.00	63.00
	AMPS	62.50	62.50	62.50	62.50	62.50	125.00	125.00	62.50	125.00	131.25	75.00	68.75	131.25	131.25
SB24N5F	KVA	28.75	43.54	47.67	48.70	49.27	95.16	96.25	51.56	100.63	27.50	28.85	50.00	100.00	105.00
	AMPS	104.17	104.17	104.17	104.17	104.17	208.33	208.33	104.17	208.33	218.75	125.00	114.58	218.75	218.75
	*DIAGRAM	B	D	D	D	D	C	C	D	C	C	B	D	C	C

Three-Phase

Catalog Number	Line Voltage	BOOSTING								BUCKING							
		399Y/230	380	430	440	460	460	480	480	440	440	460	460	480	480	500	500
	Load Voltage	480Y/277	418	473	462	506	483	528	504	400	419	438	418	457	436	455	476
SB24N.050F	KVA	0.86	0.75	0.85	1.67	0.91	1.74	0.95	1.82	0.79	1.59	1.66	0.83	1.73	0.87	0.90	1.80
	AMPS	1.04	1.04	1.04	2.08	1.04	2.08	1.04	2.08	1.15	2.19	2.19	1.15	2.19	1.15	1.15	2.19
SB24N.100F	KVA	1.73	1.51	1.71	3.33	1.83	3.49	1.91	3.64	1.59	3.18	3.32	1.66	3.46	1.73	1.80	3.61
	AMPS	2.08	2.08	2.08	4.17	2.08	4.17	2.08	4.17	2.29	4.38	4.38	2.29	4.38	2.29	2.29	4.38
SB24N.150F	KVA	2.59	2.26	2.56	5.00	2.74	5.23	2.86	5.46	2.38	4.76	4.98	2.49	5.20	2.60	2.71	5.41
	AMPS	3.13	3.13	3.13	6.25	3.13	6.25	3.13	6.25	3.44	6.56	6.56	3.44	6.56	3.44	3.44	6.56
SB24N.250F	KVA	4.32	3.77	4.27	8.34	4.56	8.71	4.76	9.09	3.97	7.94	8.30	4.15	8.66	4.33	4.51	9.02
	AMPS	5.21	5.21	5.21	10.42	5.21	10.42	5.21	10.42	5.73	10.94	10.94	5.73	10.94	5.73	5.73	10.94
SB24N.500F	KVA	8.64	7.54	8.53	16.67	9.13	17.43	9.53	18.19	7.94	15.88	16.60	8.30	17.32	8.66	9.02	18.04
	AMPS	10.42	10.42	10.42	20.83	10.42	20.83	10.42	20.83	11.46	21.88	21.88	11.46	21.88	11.46	11.46	21.88
SB24N.750F	KVA	12.96	11.31	12.80	25.01	13.69	26.14	14.29	27.28	11.91	23.82	24.90	12.45	25.98	12.99	13.53	27.06
	1AMPS	15.62	15.63	15.63	31.25	15.63	31.25	15.63	31.25	17.19	32.81	32.81	17.19	32.81	17.19	17.19	32.81
SB24N1F	KVA	17.28	15.08	17.07	33.34	18.26	34.86	19.05	36.37	15.88	31.75	33.20	16.60	34.64	17.32	18.04	36.08
	AMPS	20.83	20.83	20.83	41.67	20.83	41.67	20.83	41.67	22.92	43.75	43.75	22.92	43.75	22.92	22.92	43.75
SB24N1.5F	KVA	25.92	22.62	25.60	50.01	27.39	52.29	28.58	54.56	23.82	47.63	49.80	24.90	51.96	25.98	27.06	54.13
	AMPS	31.25	31.25	31.25	62.50	31.25	62.50	31.25	62.50	34.38	65.63	65.63	34.38	65.63	34.37	34.37	65.63
SB24N2F	KVA	34.55	30.17	34.14	66.68	36.52	69.72	38.11	72.75	31.75	63.51	66.40	33.20	69.28	34.64	36.08	72.17
	AMPS	41.67	41.67	41.67	83.33	41.67	83.33	41.67	83.33	45.83	87.50	87.50	45.83	87.50	45.83	45.83	87.50
SB24N3F	KVA	51.83	45.25	51.20	100.03	54.78	104.57	57.16	109.12	47.63	95.26	99.59	49.80	103.92	51.96	54.13	108.25
	AMPS	62.50	62.50	62.50	125.00	62.50	125.00	62.50	125.00	68.75	131.25	131.25	68.75	131.25	68.75	68.75	131.25
SB24N5F	KVA	86.39	75.42	85.34	166.71	91.29	174.29	95.26	181.87	79.39	158.77	165.99	82.99	173.21	86.60	90.21	180.42
	AMPS	104.17	104.17	104.17	208.33	104.17	208.33	104.17	208.33	114.58	218.75	218.75	114.58	218.75	114.58	114.58	218.75
No. of Transformers		3	2	2	2	2	2	2	2	2	2	2	2	2	2	2	2
*DIAGRAM		E	G	G	H	G	H	G	H	G	H	H	G	H	G	G	H

Output voltage for lower input voltage can be found by: $\frac{\text{Rated Output Voltage}}{\text{Rated Input Voltage}} \times \text{Input Actual Voltage} = \text{Output New Voltage}$.

Output KVA available at reduced input voltage can be found by: $\frac{\text{Actual Input Voltage}}{\text{Rated Input Voltage}} \times \text{Output KVA} = \text{New KVA Rating}$.